

# Hydrobox

## EHSC series

## EHPX series

## ERSC series

### INSTALLATION MANUAL

FOR INSTALLER

For safe and correct use, read this manual and the outdoor unit installation manual thoroughly before installing the hydrobox. English is the original language. The other language versions are translations of the original.

### INSTALLATIONSHANDBUCH

FÜR INSTALLATEUR

Aus Sicherheitsgründen und zur richtigen Verwendung vor der Installation der Hydrobox die vorliegende Bedienungsanleitung und die Installationsanleitung der Außeneinheit gründlich durchlesen. Die Originalsprache ist Englisch. Die anderen Sprachversionen sind vom Original übersetzt.

### MANUEL D'INSTALLATION

POUR L'INSTALLATEUR

Pour une utilisation correcte et sûre, lisez soigneusement ce manuel et le manuel d'installation de l'unité extérieure avant d'installer l'ECODAN hydrobox. L'anglais est la langue originale. Les versions fournies dans d'autres langues sont des traductions de l'original.

### INSTALLATIEHANDLEIDING

VOOR DE INSTALLATEUR

Lees voor een veilig en juist gebruik deze handleiding en de installatiehandleiding van de buiten-unit aandachtig door voordat u met de installatie van de hydrobox begint. Engels is de oorspronkelijke taal. De andere taalversies zijn vertalingen van het origineel.

### MANUAL DE INSTALACIÓN

PARA EL INSTALADOR

Para un uso correcto y seguro, lea detalladamente este manual y el manual de instalación de la unidad exterior antes de instalar la Hydrobox. El idioma original del documento es el inglés. Las versiones en los demás idiomas son traducciones del original.

### MANUALE DI INSTALLAZIONE

PER L'INSTALLATORE

Per un utilizzo sicuro e corretto, prima di installare l'Hydrobox leggere attentamente questo manuale e quello di installazione dell'unità esterna. Il testo originale è redatto in lingua inglese. Le altre versioni linguistiche rappresentano traduzioni dell'originale.

### MANUAL DE INSTALAÇÃO

PARA O INSTALADOR

Para uma utilização segura e correcta, leia este manual e o manual de instalação da unidade interior antes de instalar o permutador de calor. O idioma original é o inglês. As versões em outros idiomas são traduções do idioma original.

### INSTALLATIONSMANUAL

TIL INSTALLATØREN

Af hensyn til sikker og korrekt brug skal denne vejledning og vejledningen til udendørsenheden læses omhyggeligt, inden hydroboxenheden installeres. Engelsk er det oprindelige sprog. De andre sprogversioner er oversættelser af originalen.

### INSTALLATIONSMANUAL

FÖR INSTALLATÖREN

För säker och korrekt användning, läs denna manual och utomhusenhetens installationsmanual innan du installerar hydroboxen. Engelska är originalspråket. De övriga språkversionerna är översättningar av originalet.

### INSTALLERINGSHÅNDBOK

FOR MONTØREN

For å sikre en trygg og riktig bruk skal du lese denne håndboken og installeringshåndboken for utendørsenheten grundig før du monterer hydroboxen. Engelsk er originalspråket. De andre språkversjonene er oversettelser av originalen.

### ASENNUSOPAS

ASENTAJALLE

Lue turvallista ja asianmukaista käyttöä varten tämä opas ja ulkoyksikön asennusopas huolellisesti ennen hydroboxin asentamista. Alkuperäiskieli on englanti. Muut kieliversiot ovat alkuperäisen käännöksiä.

English (GB)

Deutsch (D)

Français (F)

Nederlands (NL)

Español (E)

Italiano (I)

Português (P)

Dansk (DE)

Svenska (SW)

Norsk (NO)

Suomi (FI)

# Contents

1. Safety Notices .....	2	4.4 Refrigerant Pipework .....	18
2. Introduction .....	2	4.5 Electrical Connection .....	18
3. Technical Information .....	3	5. System Set UP .....	21
■ Product specification .....	3	5.1 Dip Switch Functions.....	21
■ Component Parts .....	4	5.2 Connecting inputs/outputs .....	22
■ Technical Drawings .....	7	■ Signal inputs .....	22
■ Unit Compatibility .....	9	■ Thermistor inputs .....	22
■ Water circuit diagram .....	9	■ Outputs .....	23
■ Local system .....	10	5.3 Wiring for 2-zone temperature control .....	23
4. Installation .....	11	5.4 Installation procedure for DHW tank.....	24
4.1 Location .....	11	5.5 Remote Controller Options .....	26
■ Transportation and Handling .....	11	■ 1-zone temperature control.....	26
■ Suitable Location .....	11	■ 2-zone temperature control.....	27
■ Service access diagrams .....	11	■ Remote Installation of Main Controller .....	28
■ Room Thermostat .....	11	5.6 Using SD memory card.....	29
■ Repositioning hydrobox.....	11	5.7 Main Controller .....	30
■ Mounting procedure .....	12	■ Setting the Main Controller .....	33
4.2 Water Quality and System Preparation .....	14	■ Main Settings Menu .....	33
■ General .....	14	■ Initial Settings .....	33
■ Anti-Freeze .....	14	■ Domestic Hot Water (DHW)/Legionella Prevention ...	34
■ New Installation (primary water circuit).....	14	■ Heating/Cooling .....	36
■ Existing Installation (primary water circuit) .....	14	■ Holiday mode .....	37
■ Minimum amount of water required in the space		■ Schedule timer .....	37
heating circuit .....	14	■ Service Menu.....	39
■ How to access Internal Components and Control		6. Commissioning .....	46
and Electrical Box .....	14	■ Pre-commissioning Checklist .....	46
4.3 Water Pipe Work.....	15	7. Service and Maintenance .....	47
■ Hot Water Pipework.....	15	■ Basic Troubleshooting for Hydrobox.....	47
■ Hydraulic filter work (ONLY EHPT series) .....	15	■ Error Codes .....	48
■ Pipework Connections .....	15	■ Annual Maintenance .....	49
■ Insulation of Pipework.....	15	■ Annual Maintenance Log Book .....	49
■ Discharge Pipework .....	15	■ Engineers Forms.....	50
■ Filling the System (Primary Circuit).....	15	8. Supplementary information .....	52
■ Sizing Expansion Vessels .....	16	■ Refrigerant collecting (pumpdown) for split model	
■ Water Circulation Pump Characteristics .....	16	systems only.....	52
■ Safety device connections.....	17	■ Back-up operation of boiler .....	52
■ Piping diagram of 2-zone temperature control .....	17	■ Multiple outdoor units control .....	52

GB

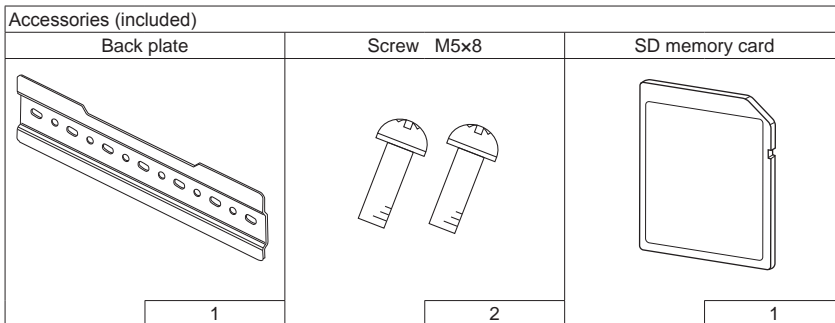

## Abbreviations and glossary

No.	Abbreviations/Word	Description
1	Compensation curve mode	Space heating incorporating outdoor ambient temperature compensation
2	COP	Coefficient of Performance the efficiency of the heat pump
3	Cooling mode	Space cooling through fan-coils or underfloor cooling (Refer to Item no. 20 in this list.)
4	DHW mode	Domestic hot water heating mode for showers, sinks, etc
5	Flow rate	Speed at which water circulates around the primary circuit
6	Flow temperature	Temperature at which water is delivered to the primary circuit
7	Freeze stat. function	Heating control routine to prevent water pipes freezing
8	FTC4	Flow temperature controller, the circuit board in charge of controlling the system
9	Heating mode	Space heating through radiators or Underfloor heating (Refer to Item no. 21 in this list.)
10	Hydrobox	Indoor unit housing the component plumbing parts (NO DHW tank)
11	Legionella	Bacteria potentially found in plumbing, showers and water tanks that may cause Legionnaires disease
12	LP mode	Legionella prevention mode – a function on systems with water tanks to prevent the growth of legionella bacterium
13	Packaged model	Plate heat exchanger in the outdoor heat pump unit
14	PRV	Pressure relief valve
15	Refrigerant	A compound used within the heat pump cycle that goes through a phase change from gas to liquid
16	Return temperature	Temperature at which water is delivered from the primary circuit
17	Split model	Plate heat exchanger in the indoor unit
18	TRV	Thermostatic radiator valve – a valve on the entrance or exit of the radiator panel to control the heat output
19	Underfloor cooling	A system of water carrying pipes under the floor, that cools the floor surface to cool the room/space.
20	Underfloor heating	A system of water carrying pipes under the floor, that warms the floor surface to heat the room/space.

# 1 Safety Notices

Please read the following safety precautions carefully.

**⚠ WARNING:**  
Precautions that must be observed to prevent injuries or death.

**⚠ CAUTION:**  
Precautions that must be observed to prevent damage to unit.

**This installation manual along with the user manual should be left with the product after installation for future reference.**  
**Mitsubishi Electric is not responsible for the failure of locally-supplied and field-supplied parts.**

- Be sure to perform periodical maintenance.
- Be sure to follow your local regulations.
- Be sure to follow the instructions provided in this manual.

## ⚠ WARNING

### Mechanical

- The hydrobox and outdoor units must not be installed, disassembled, relocated, altered or repaired by the user. Ask an authorised installer or technician. If the unit is installed improperly or modified after installation by the user water leakage, electric shock or fire may result.
- The outdoor unit should be securely fixed to a hard level surface capable of bearing its weight.
- The hydrobox should be positioned on a hard vertical surface capable of supporting its filled weight to prevent excessive sound or vibration.
- Do not position furniture or electrical appliances below the outdoor unit or hydrobox.
- The discharge pipework from the emergency/safety devices of the hydrobox should be installed according to local law.
- Only use accessories and replacement parts authorised by Mitsubishi Electric ask a qualified technician to fit the parts.

### Electrical

- All electrical work should be performed by a qualified technician according to local regulations and the instructions given in this manual.
- The units must be powered by a dedicated power supply and the correct voltage and circuit breakers must be used.
- Wiring should be in accordance with national wiring regulations. Connections must be made securely and without tension on the terminals.
- Earth unit correctly.

### General

- Keep children and pets away from both the hydrobox and outdoor units.
- Do not use the hot water produced by the heat pump directly for drinking or cooking. This could cause illness to the user.
- Do not stand on the units.
- Do not touch switches with wet hands.
- Annual maintenance checks on both the hydrobox and the outdoor unit should be done by qualified person.
- Do not place contains with liquids in on top of the hydrobox. If they leak or spill onto the hydrobox damage to the unit and/or fire could occur.
- Do not place any heavy items on top of the hydrobox.
- When installing or relocating, or servicing the hydrobox, use only the specified refrigerant (R410A) to charge the refrigerant lines. Do not mix it with any other refrigerant and do not allow air to remain in the lines. If air is mixed with the refrigerant, then it can be the cause of abnormal high pressure in the refrigerant line, and may result in an explosion and other hazards.
- The use of any refrigerant other than that specified for the system will cause mechanical failure or system malfunction or unit breakdown. In the worst case, this could lead to a serious impediment to securing product safety.
- In heating mode, to avoid the heat emitters being damaged by excessively hot water, set the target flow temperature to a minimum of 2°C below the maximum allowable temperature of all the heat emitters. For Zone2, set the target flow temperature to a minimum of 5°C below the maximum allowable flow temperature of all the heat emitters in Zone2 circuit.

## ⚠ CAUTION

- Use clean water that meets local quality standards on the primary circuit.
- The outdoor unit should be installed in an area with sufficient airflow according to the diagrams in the outdoor unit installation manual.
- The hydrobox should be located inside to minimise heat loss.
- Water pipe-runs on the primary circuit between outdoor and indoor unit should be kept to a minimum to reduce heat loss.
- Ensure condensate from outdoor unit is piped away from the base to avoid puddles of water.
- Remove as much air as possible from water circuit.
- Refrigerant leakage may cause suffocation. Provide ventilation in accordance with EN378-1.
- Be sure to wrap insulation around the piping. Direct contact with the bare piping may result in burns or frostbite.
- Never put batteries in your mouth for any reason to avoid accidental ingestion.
- Battery ingestion may cause choking and/or poisoning.
- Install the unit on a rigid structure to prevent excessive sound or vibration during operation.
- If power to the hydrobox is to be turned off (or system switched off) for a long time, the water should be drained.
- Preventative measures should be taken against water hammer, such as installing a Water Hammer Arrestor on the primary water circuit, as directed by the manufacturer.
- In order to prevent condensation on emitters, adjust flow temperature appropriately and also set the lower limit of the flow temperature on site.

As for the handling of refrigerant, refer to the outdoor unit installation manual.

# 2 Introduction

The purpose of this installation manual is to instruct competent persons how to safely and efficiently install and commission the hydrobox system. The target readers of this manual are competent plumbers and/or refrigeration engineers

who have attended and passed the requisite Mitsubishi Electric product training and have appropriate qualifications for installation of an unvented hot water hydrobox specific to their country.

## ■ Product specification

Model name	EHSC-VM2B	EHSC-VM6B	EHSC-YM9B	EHSC-TM9B	EHSC-VM6EB	EHSC-YM9EB	EHPX-VM2B	EHPX-VM6B	EHPX-YM9B	ERSC-VM2B
Overall unit dimensions (Height×Width×Depth)	800×530×360 mm									
Weight (empty)	51 kg	53 kg	53 kg	53 kg	49 kg	49 kg	39 kg	41 kg	41 kg	860×530×360 mm 54 kg
Weight (full)	57 kg	59 kg	59 kg	59 kg	55 kg	55 kg	44 kg	46 kg	46 kg	60 kg
Plate heat exchanger	✓	✓	✓	✓	✓	✓	—	—	—	✓
Cooling mode	NOT available									
Unvented expansion vessel (Primary circuit)	Nominal volume 10 L Charge pressure 0.1 MPa (1 bar)									
Safety device	Control thermostat									
	Pressure relief valve									
	Flow switch									
	Manual reset thermostat									
Booster heater	Thermal cut-out (for dry run prevention) 90°C 121°C									
Primary circuit circulating pump	Grundfos UPM2 25 70-180									
Connections	Water	28 mm compression (Primary circuit)								
	Refrigerant (R410A)	Liquid	9.52 mm		—		—		G1 (Male)	
Target temperature range	Gas	15.88 mm		—		—		—		9.52 mm
	Heating	25 - 60°C								
	Cooling	—								
	Room temperature	10 - 30°C								
Ambient *1	0 - 35°C (≤ 80%RH)									
Guaranteed operating range	Heating	See outdoor unit spec table.								
	Cooling	—								
Electrical data	Power supply (Phase, voltage, frequency)	~N, 230 V, 50 Hz								
	Breaker (*when powered from independent source)	10 A								
Booster heater	Power supply (Phase, voltage, frequency)	~N, 230 V, 50 Hz	3~ 400 V, 50 Hz	3~ 230 V, 50 Hz	~N, 230 V, 50 Hz	3~ 400 V, 50 Hz	~N, 230 V, 50 Hz	~N, 230 V, 50 Hz	3~ 400 V, 50 Hz	~N, 230 V, 50 Hz
	Capacity	2 kW	3 kW + 6 kW	3 kW + 6 kW	2 kW + 4 kW	3 kW + 6 kW	2 kW	2 kW + 4 kW	3 kW + 6 kW	2 kW
	Current	9 A	13 A	23 A	26 A	13 A	9 A	26 A	13 A	9 A
	Breaker	16 A	16 A	32 A	32 A	16 A	16 A	32 A	16 A	16 A

&lt; Table 3.1 &gt;

## Optional extras

- Wireless Remote Controller
- Wireless Receiver
- Remote sensor
- Tank thermostat (THW5)
- Joint pipe (15.88 → 12.7)
- Joint pipe (9.52 → 6.35)
- Thermistor
- High temperature thermistor

- PAC-WT50R-E
- PAC-WR51R-E
- PAC-SE51TS-E
- PAC-TH011TK-E
- PAC-SH50RJ-E
- PAC-SH30RJ-E
- PAC-TH011-E
- PAC-TH011HT-E

\*1 The environment must be frost-free.

\*2 Low ambient cooling is NOT allowed.

See outdoor unit spec table (min. 10°C). \*2

### 3 Technical Information

#### ■ Component Parts

#### <EHSC-\*M\*B> (Split model system)

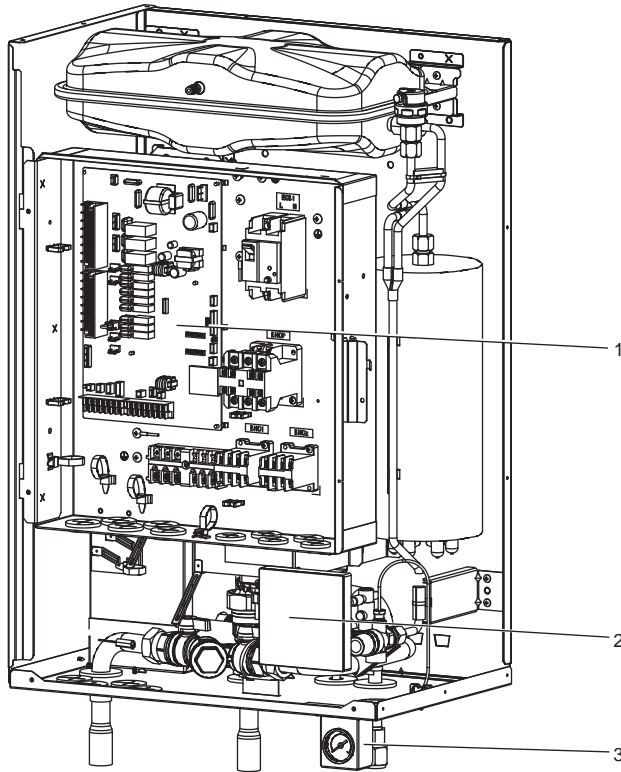

<Figure 3.1>

Number	Component
1	Control and electrical box
2	Main controller
3	Manometer
4	Expansion vessel *(Except EHSC-*M*EB)
5	Expansion vessel charge valve
6	Automatic air vent
7	Booster heater
8	Drain cock
9	Water circulation pump
10	Pressure relief valve
11	Flow switch
12	Plate heat exchanger
13	Strainer valve
A	Inlet from space heating/Indirect DHW tank (primary return)
B	Outlet to space heating/Indirect DHW tank (primary flow)
C	Refrigerant (Liquid)
D	Refrigerant (Gas)
E	Discharge from pressure relief valve (installer to pipe connect to suitable drain point)

<Table 3.2>

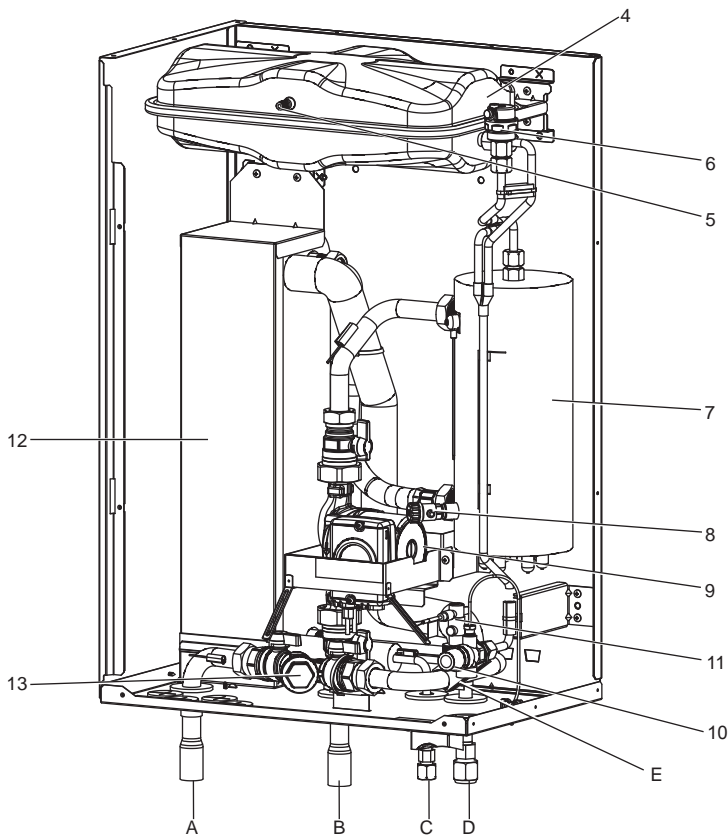

<Figure 3.2>

\*For installation of EHSC-\*M\*EB model, make sure to install a primary-side expansion vessel in the field. (See Figure 4.3.3.)

#### <EHPX> (Packaged model system)

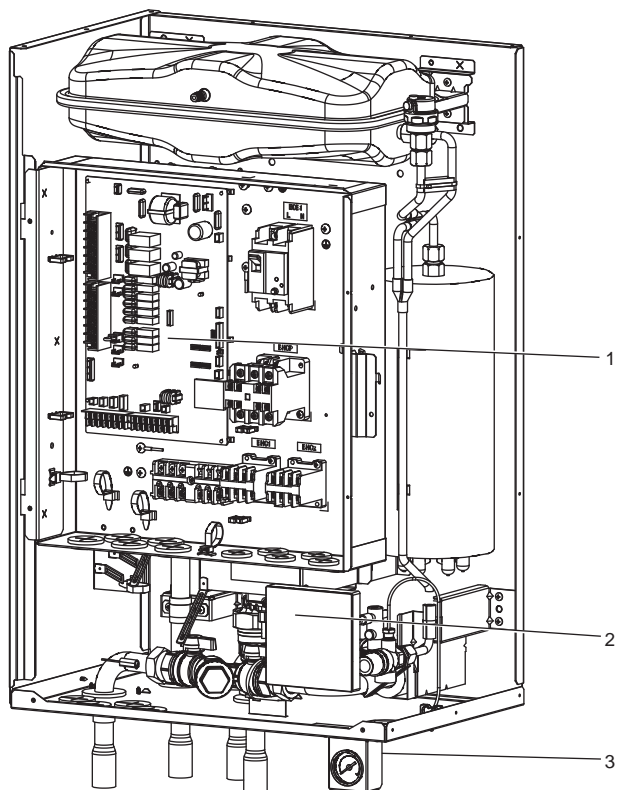

<Figure 3.3>

Number	Component
1	Control and electrical box
2	Main controller
3	Manometer
4	Expansion vessel
5	Expansion vessel charge valve
6	Automatic air vent
7	Booster heater
8	Drain cock
9	Water circulation pump
10	Pressure relief valve
11	Flow switch
13	Strainer valve
A	Inlet from space heating/Indirect DHW tank (primary return)
B	Inlet from heat pump
C	Outlet to heat pump
D	Outlet to space heating/Indirect DHW tank (primary flow)
E	Discharge from pressure relief valve (installer to pipe connect to suitable drain point)

<Table 3.3>

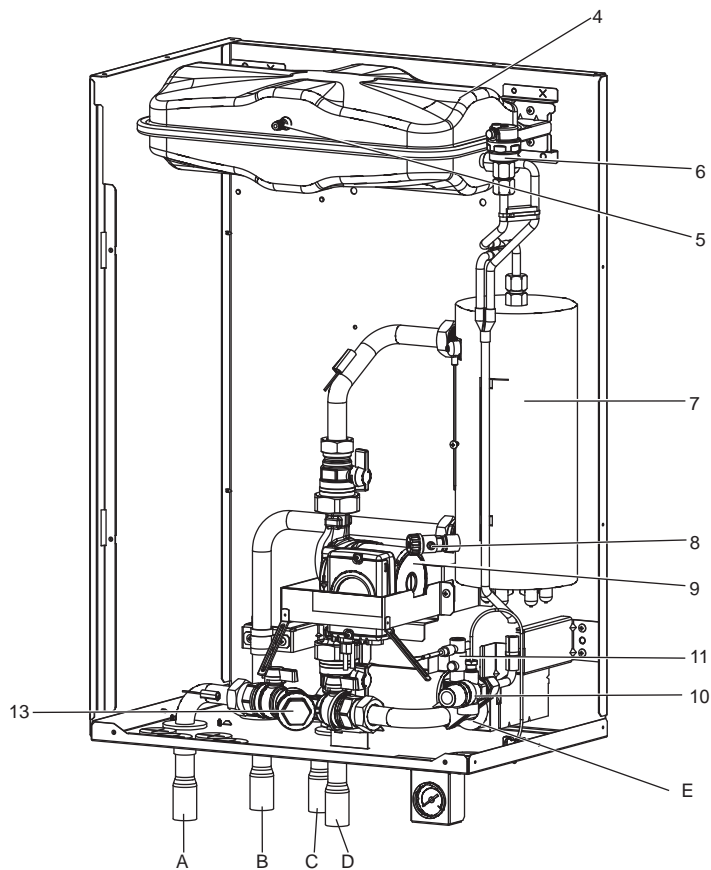

<Figure 3.4>

#### <ERSC> (Split model system for heating and cooling)

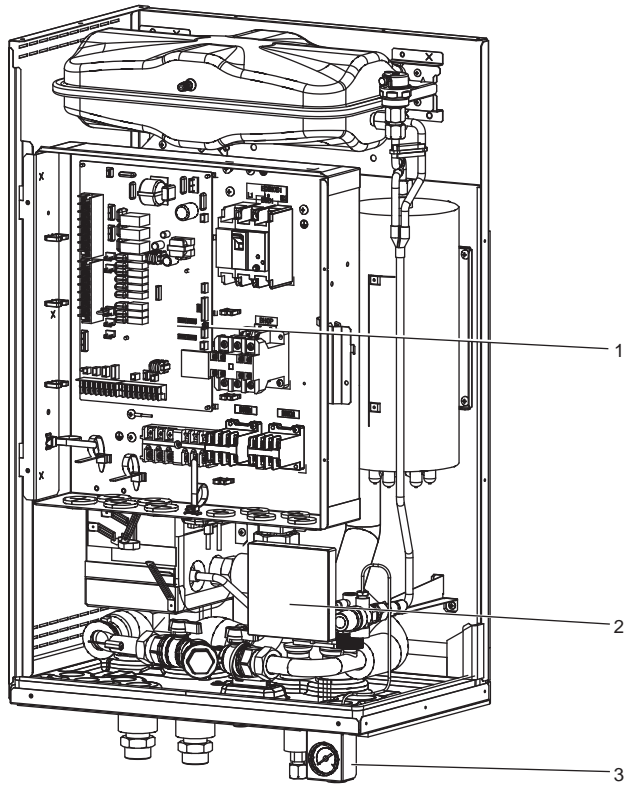

<Figure 3.5>

Number	Component
1	Control and electrical box
2	Main controller
3	Manometer
4	Expansion vessel
5	Expansion vessel charge valve
6	Automatic air vent
7	Booster heater
8	Drain cock
9	Water circulation pump
10	Pressure relief valve
11	Flow switch
12	Plate heat exchanger
13	Strainer valve
14	Drain pan
A	Inlet from space heating/Indirect DHW tank (primary return)
B	Outlet to space heating/Indirect DHW tank (primary flow)
C	Refrigerant (Liquid)
D	Refrigerant (Gas)
E	Discharge from pressure relief valve (installer to pipe connect to suitable drain point)

<Table 3.4>

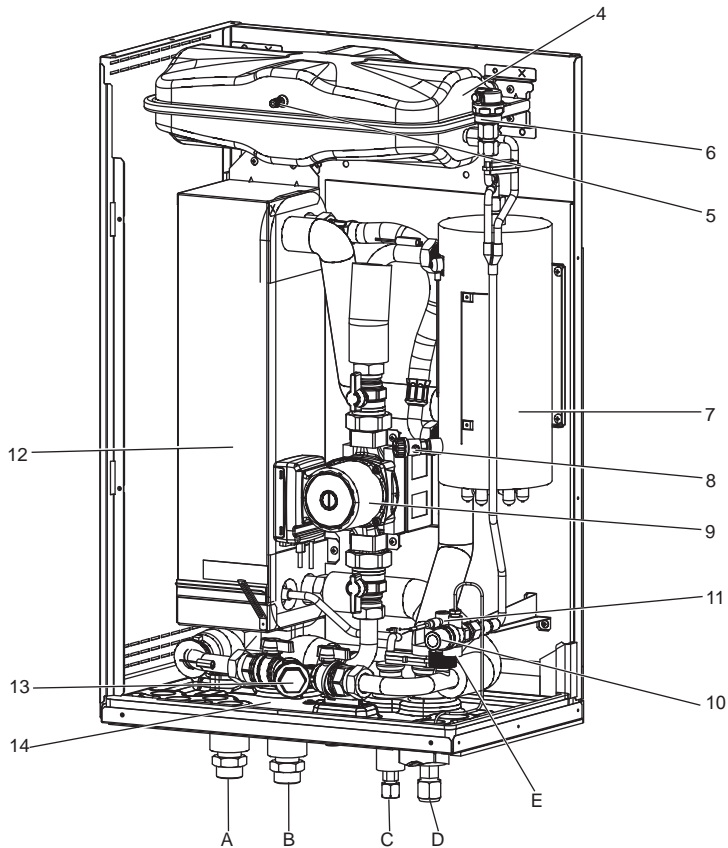

<Figure 3.6>

### 3 Technical Information

#### ■ Technical Drawings

#### <EHSC> (Split model system)

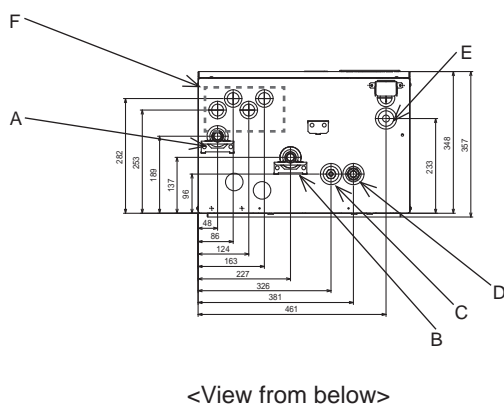
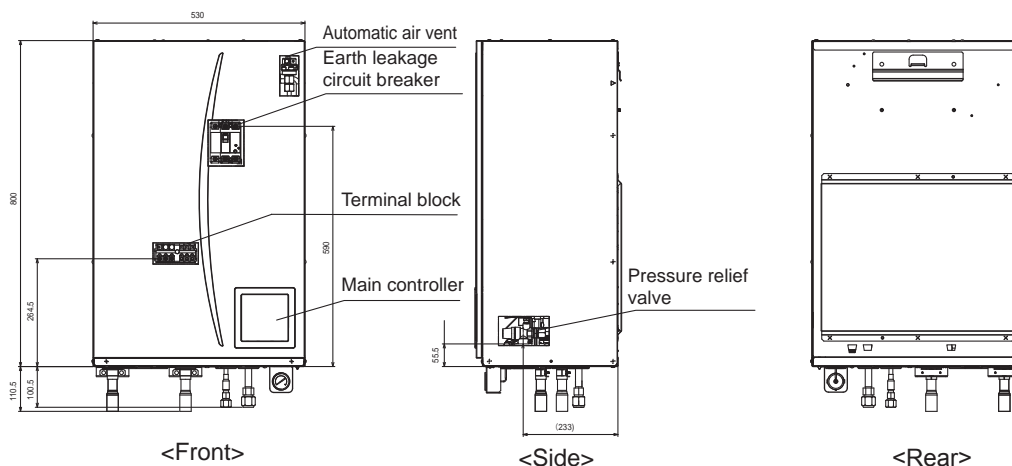

<View from below>

Letter	Pipe description	Connection size/type
A	Space heating/Indirect DHW tank (primary) return connection	28 mm/Compression
B	Space heating/Indirect DHW tank (primary) flow connection	28 mm/Compression
C	Refrigerant (Liquid)	9.52 mm/Flare
D	Refrigerant (Gas)	15.88 mm/Flare
E	Discharge pipe (by installer) from pressure relief valve	G1/2" female (valve port within hydrobox casing)
F	Electrical cable inlets ① ② ③ ④	For inlets ① and ②, run low-voltage wires including external input wires and thermistor wires. For inlets ③ and ④, run high-voltage wires including power cable, indoor-outdoor cable, and external output wires. *For a wireless receiver (option) cable, use inlet ①.

<Table 3.5>

#### <EHPX> (Packaged model system)

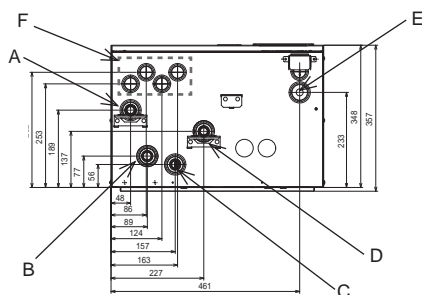
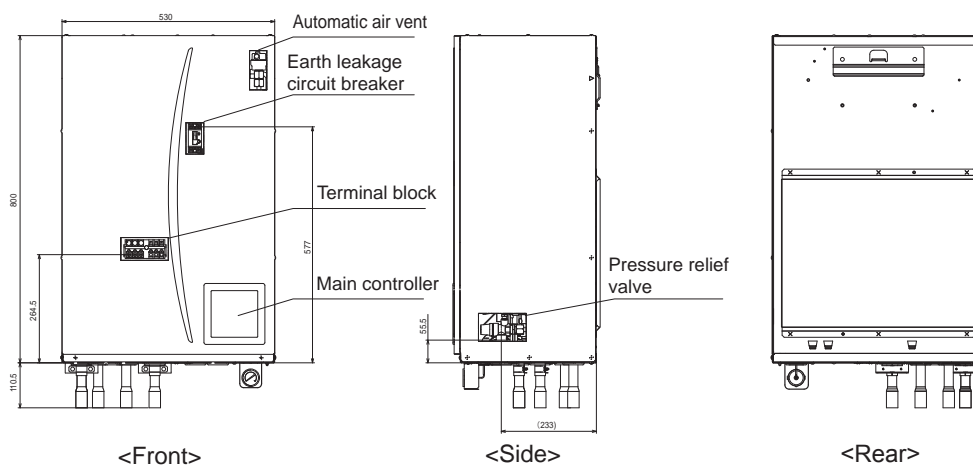

<View from below>

Letter	Pipe description	Connection size/type
A	Space heating/Indirect DHW tank (primary) return connection	28 mm/Compression
B	Flow connection from heat pump	28 mm/Compression
C	Return connection to heat pump	28 mm/Compression
D	Space heating/Indirect DHW tank (primary) flow connection	28 mm/Compression
E	Discharge pipe (by installer) from pressure relief valve	G1/2" female (valve port within hydrobox casing)
F	Electrical cable inlets ① ② ③ ④	For inlets ① and ②, run low-voltage wires including external input wires and thermistor wires. For inlets ③ and ④, run high-voltage wires including power cable, indoor-outdoor cable, and external output wires. *For a wireless receiver (option) cable, use inlet ①.

<Table 3.6>



### 3 Technical Information

#### <ERSC> (Split model system)

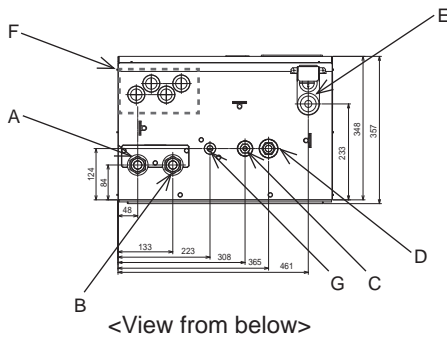
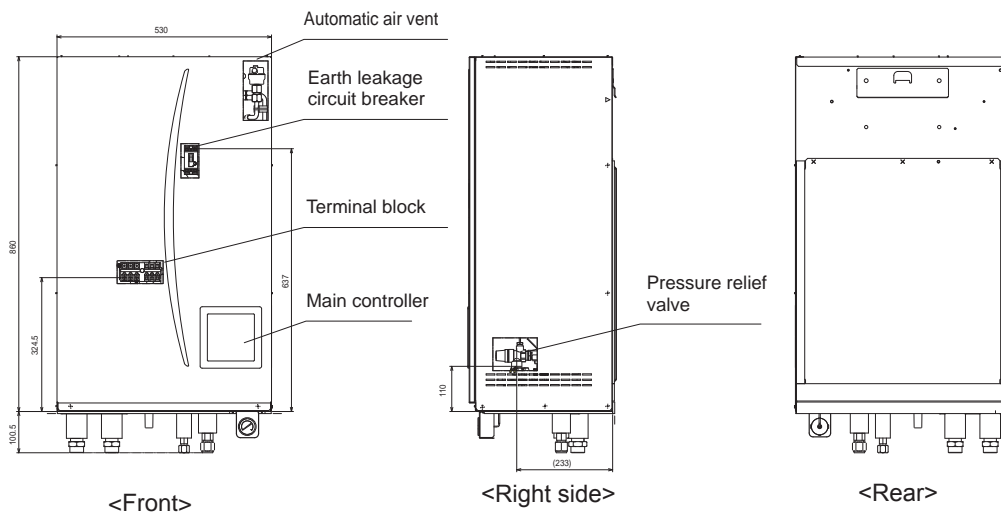

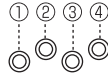
Letter	Pipe description	Connection size/type
A	Space heating and cooling/ Indirect DHW tank (primary) return connection	G1 nut
B	Space heating and cooling/ Indirect DHW tank (primary) flow connection	G1 nut
C	Refrigerant (Liquid)	9.52 mm/Flare
D	Refrigerant (Gas)	15.88 mm/Flare
E	Discharge pipe (by installer) from pressure relief valve	G1/2" female (valve port within hydrobox casing)
F	Electrical cable inlets 	For inlets ① and ②, run low-voltage wires including external input wires and thermistor wires. For inlets ③ and ④, run high-voltage wires including power cable, indoor-outdoor cable, and external output wires. *For a wireless receiver (option) cable, use inlet ①.
G	Drain socket	O.D. ø20

<Table 3.7>

### 3 Technical Information

#### Unit Compatibility

Outdoor unit		Hydrobox	EHSC-VM2B	EHSC-VM6B	EHSC-YM9B	EHSC-TM9B	EHSC-VM6EB	EHSC-YM9EB	EHPX-VM2B	EHPX-VM6B	EHPX-YM9B	ERSC-VM2B
Packaged-type	PUHZ-W50-85 PUHZ-HW112-140								✓	✓	✓	
Split-type	PUHZ-RP35-140 PUHZ-HRP71-125 PUHZ-SW40-120 PUHZ-SHW80-140 PUHZ-FRP		✓	✓	✓	✓	✓	✓				✓*1

\*1 Not available for connection to PUHZ-FRP.

<Table 3.8>

#### Water circuit diagram

<EHSC> (Split model system)  
<ERSC> (Split model system for heating and cooling)

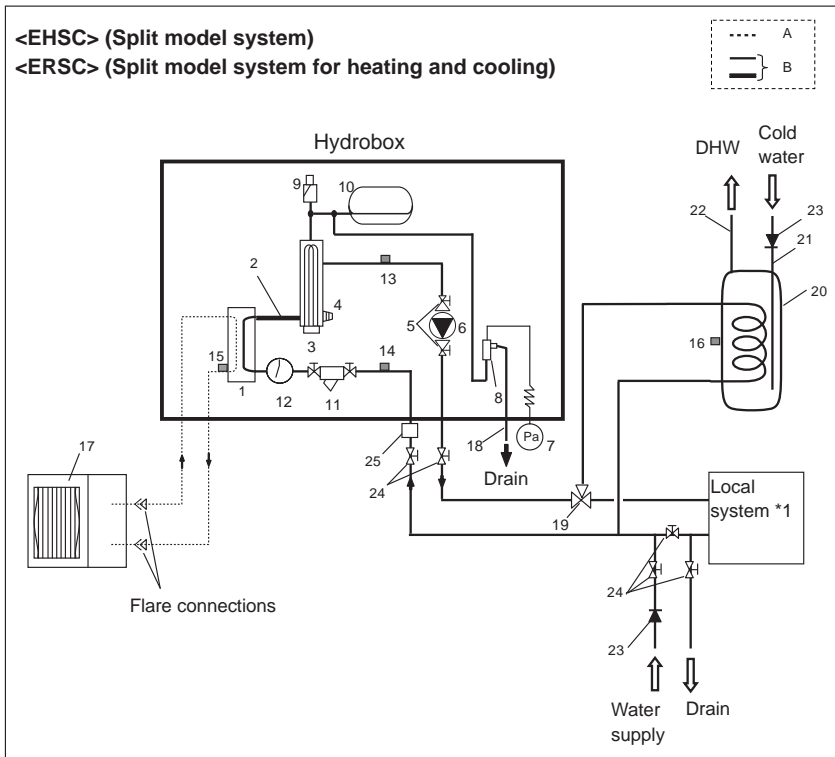

<Figure 3.7>

- A. Refrigerant pipe
- B. Water pipe
- 1. Plate heat exchanger
- 2. Flexible hose
- 3. Booster heater 1,2
- 4. Drain cock (booster heater)
- 5. Pump valve
- 6. Water circulation pump 1
- 7. Manometer
- 8. Pressure relief valve
- 9. Automatic air vent
- 10. Expansion vessel (except EHSC-\*M\*EB)
- 11. Strainer valve
- 12. Flow switch
- 13. THW1
- 14. THW2
- 15. TH2
- 16. THW5 (optional part PAC-TH011TK-E)
- 17. Outdoor unit
- 18. Drain pipe (field supply)
- 19. 3-way valve (field supply)
- 20. DHW indirect unvented tank (field supply)
- 21. Cold water inlet pipe (field supply)
- 22. DHW outlet connection (field supply)
- 23. Back flow prevention device (field supply)
- 24. Isolating valve (field supply)
- 25. Magnetic filter is recommended (field supply).
- 26. Strainer (field supply)

\*1 Refer to page 10.

<EHPX> (Packaged model system)

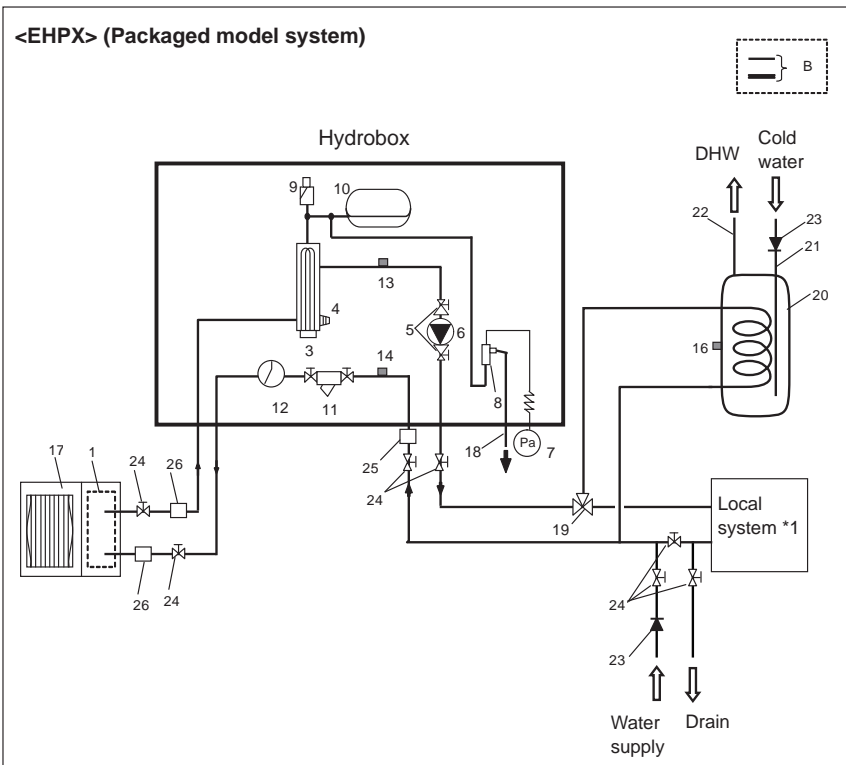

<Figure 3.8>

#### Note

- Be sure to follow your local regulations to perform system configuration of the DHW connections.
- DHW connections are not included in the hydrobox package. All required parts are to be sourced locally.
- To enable draining of the hydrobox an isolating valve should be positioned on both the inlet and outlet pipework.
- Be sure to install a strainer, on the inlet pipe work to the hydrobox.
- Suitable drain pipework should be attached to all relief valves in accordance with your country's regulations.
- A backflow prevention device must be installed on water supply pipework (IEC 61770).
- When using components made from different metals or connecting pipes made of different metals insulate the joints to prevent a corrosive reaction taking place which will damage the pipework.

### 3 Technical Information

#### Local system

##### 1-zone temperature control

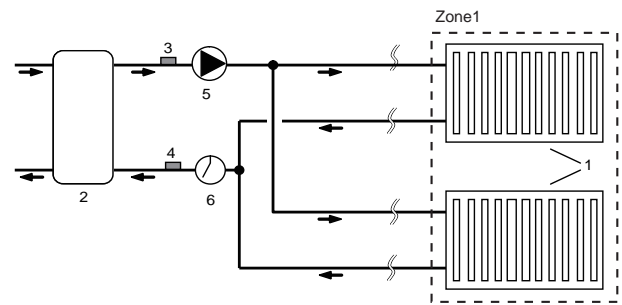
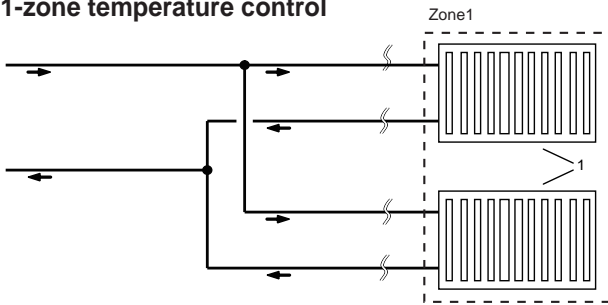

##### 2-zone temperature control

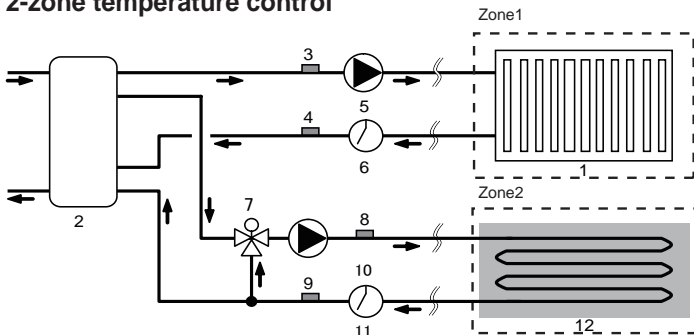

##### 1-zone temperature control with boiler

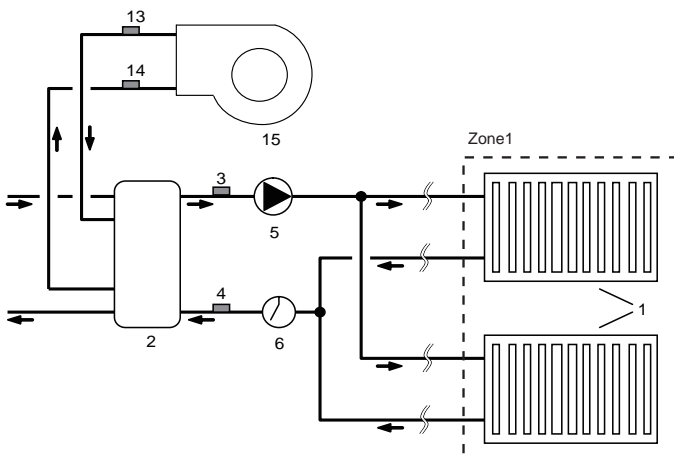

##### 2-zone temperature control with boiler

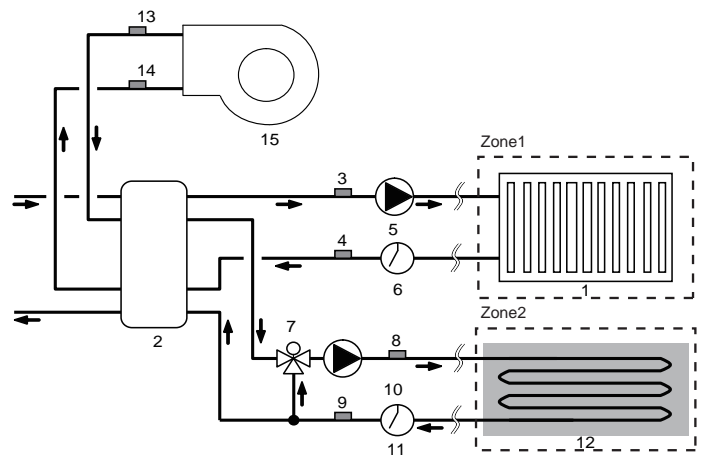

1. Zone1 heat emitters (e.g. radiator, fan coil unit) (field supply)
2. Mixing tank (field supply)
3. Zone1 flow water temp. thermistor (THW6)
4. Zone1 return water temp. thermistor (THW7) } Optional part : PAC-TH011-E
5. Zone1 water circulation pump (field supply)
6. Zone1 flow switch (field supply) \*
7. Motorized mixing valve (field supply)
8. Zone2 flow water temp. thermistor (THW8)
9. Zone2 return water temp. thermistor (THW9) } Optional part : PAC-TH011-E
10. Zone2 water circulation pump (field supply)
11. Zone2 flow switch (field supply) \*
12. Zone2 heat emitters (e.g. underfloor heating) (field supply)
13. Boiler flow water temp. thermistor (THWB1)
14. Boiler return water temp. thermistor (THWB2) } Optional part : PAC-TH011HT-E
15. Boiler

\* Flow switch specifications: DC13 V / 0.1 mA / Both normally-open and normally-closed types can be used. (Set Dip switch 3 to select the logics. Refer to "5.1 Dip switch function".)

**Note:** Cooling mode cannot run under 2-zone temperature control but can run both in Zone1 and Zone2 under 1-zone temperature control.

## 4 Installation

### <Preparation before the installation and service>

- Prepare the proper tools.
- Prepare the proper protection.
- Allow parts to cool before attempting any maintenance.
- Provide adequate ventilation.
- After stopping the operation of the system, turn off the power-supply breaker and remove the power plug.
- Discharge the capacitor before commencing work involving the electric parts.

### <Precautions during service>

- Do not perform work involving electric parts with wet hands.
- Do not pour water or liquid into the electric parts.
- Do not touch the refrigerant.
- Do not touch the hot or cold surfaces in the refrigerant cycle.
- When the repair or the inspection of the circuit needs to be done without turning off the power, exercise great caution not to touch any live parts.

## 4.1 Location

### ■ Transportation and Handling

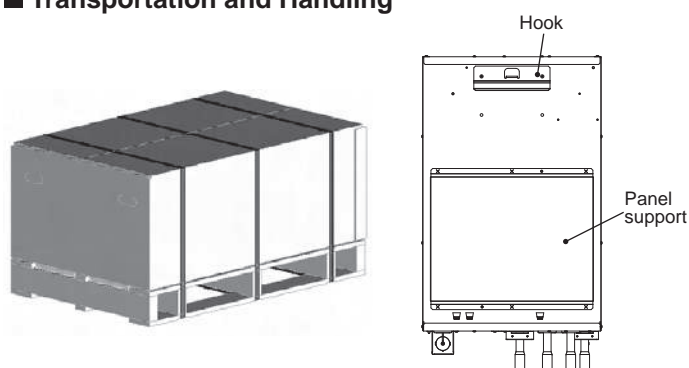

<Figure 4.1.1>

Hydrobox is delivered on a wooden pallet base with cardboard protection.

Care should be taken when transporting the hydrobox so that the casing is not damaged by impact. Do not remove the protective packaging until hydrobox has reached its final location. This will help protect the structure and control panel.

#### Note:

- The hydrobox should **ALWAYS** be moved by a minimum of 2 people.
- Do **NOT** hold piping when moving the hydrobox.

### ■ Suitable Location

Before installation the hydrobox should be stored in a frost-free weatherproof location. Units must **NOT** be stacked.

- The hydrobox should be installed indoors in a frost free weather proof location.
- The hydrobox should be positioned on a level wall capable of supporting it's filled weight.
- To find out the weight, refer to "3. Technical Information".
- Care should be taken that minimum distances around and in front of the unit for service access are observed <Figure 4.1.3>.
- Secure the hydrobox to prevent it being knocked over accidentally or during earthquakes.
- The hook and panel supports should be used to fix the hydrobox to the wall. <Fig. 4.1.2>
- Install the hydrobox where it is not exposed to water/excessive moisture.

### ■ Service access diagrams

Service access	
Parameter	Dimension (mm)
a	200
b	150
c	500
d	500

<Table 4.1.1>

Sufficient space **MUST** be left for the provision of discharge pipework as detailed in National and Local building regulations.

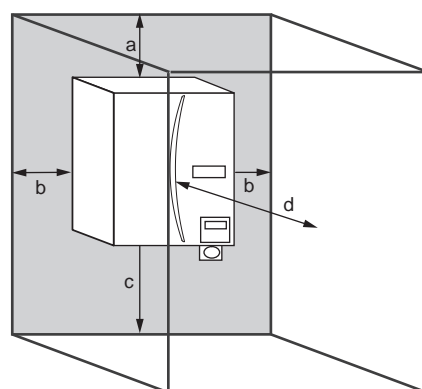

<Figure 4.1.3>

Service access

The hydrobox must be located indoors and in a frost-free environment, for example in a utility room.

### ■ Room Thermostat

If fitting a new room thermostat for this system;

- Position it out of direct sunlight and draughts
- Position it away from internal heat sources
- Position it in a room without a TRV on the radiator/heat emitter
- Position it on an internal wall

Note: Do not position the thermostat excessively close to the wall. The thermostat may detect the temperature of the wall, which could affect appropriate control of the room temperature.

- Position it approx. 1.5 m above floor level

### ■ Repositioning hydrobox

If you need to move the hydrobox to a new position **FULLY DRAIN** it before moving to avoid damage to the unit.

**Note: Do NOT hold piping when moving the hydrobox.**

# 4 Installation

## ■ Mounting procedure

1. Install the included back plate accessory.
  - \* When installing the back plate, use field-supplied screws and compatible fixing plugs.

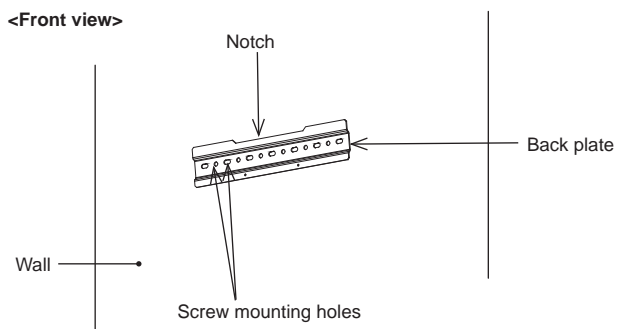

<Figure 4.1.4>

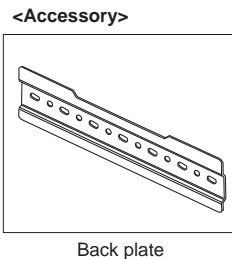

- Ensure that the notch is positioned at the TOP of the back plate. The back plate is provided with screw mounting holes that are round or oval. To prevent the unit from falling off the wall, choose the appropriate number of holes or hole positions and horizontally secure the back plate to the appropriate wall location.

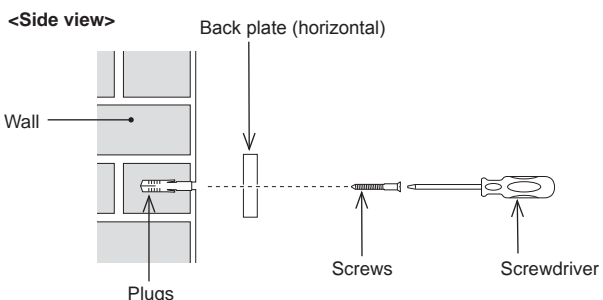

<Figure 4.1.5>

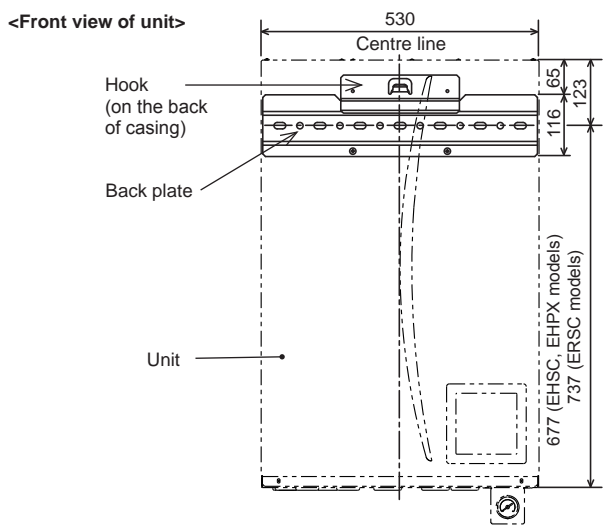

<Figure 4.1.6>

- Figure 4.1.6 shows the relative positions between the unit and the wall secured back plate. Referring to the <Figure 4.1.3> Service access, install the back plate.

2. Insert the hook on the back of the hydrobox behind the notch of the back plate.
  - \*The lifting up of the hydrobox is facilitated by first tilting the unit forward using the included packaging cushioning.

Note: Hold the MAIN BODY of the hydrobox when carrying or mounting the hydrobox to a wall. Holding and supporting the unit by the manometer, water pipe, or refrigerant pipe may result in breakdown of the components and impact on unit's conditions of warranty.

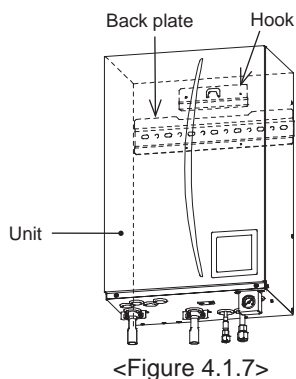

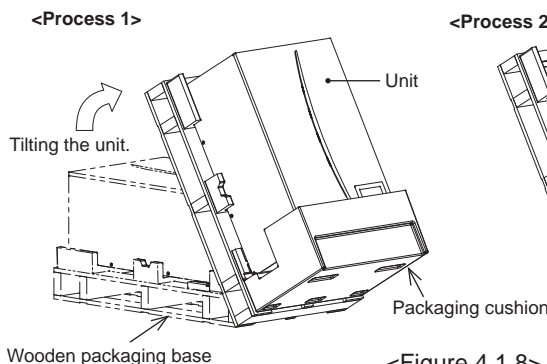

<Figure 4.1.7>



<Figure 4.1.8>

# 4 Installation

- i) Each of the right and left side panels has a  mark indication. Lift up the unit so that the  marks are positioned above the top edge of the back plate as shown below.

<Side view of unit>

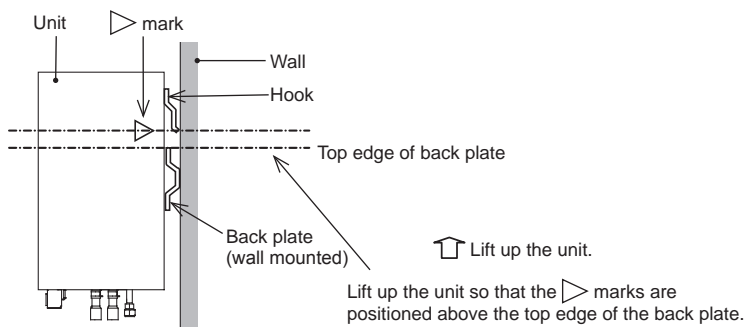

<Figure 4.1.9>

- ii) The back plate and the unit share the same width. When mounting the unit, the centre lines of the back plate and the unit can be aligned by keeping the right and left edges of the back plate within the width of the unit. The hook on the unit can then be attached to the notch on the back plate. (When mounting, the casing's lower panel support should be in contact with the wall surface.)

<Front view of unit>

To assist in fixing the unit's hook on to the notch on the back plate, first line up the centre lines.

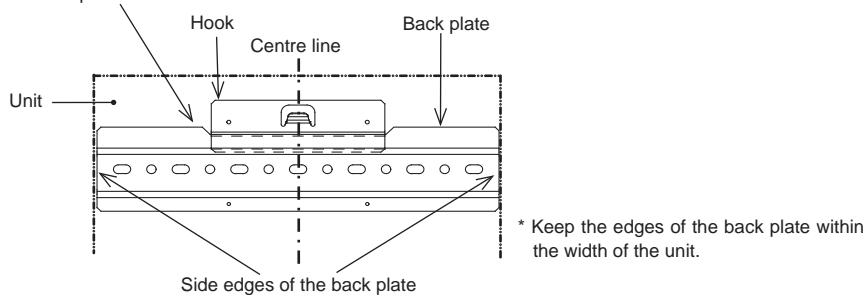

<Figure 4.1.10>

- iii) Check and ensure that the  mark is positioned and properly engaged at the bent section level on the back plate as shown.

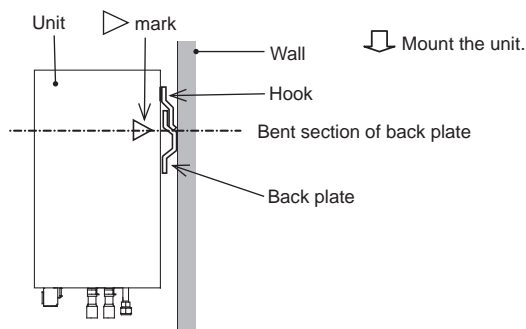

<Figure 4.1.11>

3. Referring to "How to access Internal Components and Control and Electrical Box", fix the unit and the back plate using the included 2 screws (accessory items).

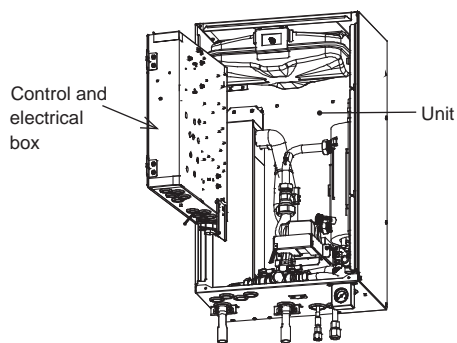

<Figure 4.1.12>

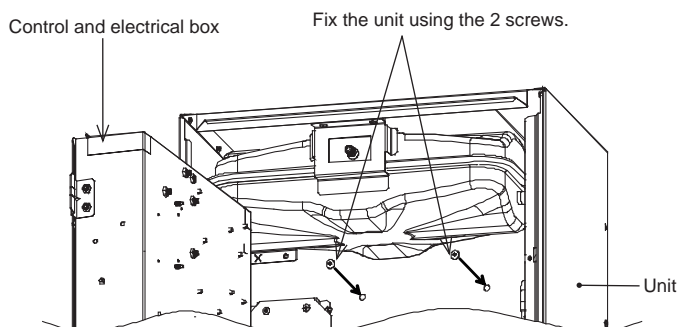

<Figure 4.1.13>

<Accessory>

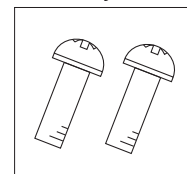

Screw M5x8

Caution) BEFORE performing field piping, be sure to fit and tighten these two screws. Otherwise, the hook could be disengaged, and the unit could fall down.

## 4 Installation

### 4.2 Water Quality and System Preparation

#### ■ General

- Water quality should be to European Directive 98/83 EC standards.
  - pH value of 6.5-8.0 (Recommended: pH6.5 - 7.5)
  - Calcium ≤ 100 mg/l
  - Chlorine ≤ 100 mg/l
  - Iron/Manganese ≤ 0.5 mg/l
- In known hard water areas, to prevent/minimise scaling, it is beneficial to restrict the routine stored water temperature (DHW max. temp.) to 55°C.

#### ■ Anti-Freeze

Anti-freeze solutions MUST use propylene glycol with a toxicity rating of Class 1 as listed in Clinical Toxicology of Commercial Products, 5th Edition.

**Note: Ethylene glycol is toxic and must NOT be used in the primary water circuit in case of any cross-contamination of the potable circuit.**

#### ■ New Installation (primary water circuit)

- Before connecting outdoor unit, thoroughly cleanse pipework of building debris, solder etc using a suitable chemical cleansing agent.
- Flush the system to remove chemical cleanser.
- For all packaged model systems add a combined inhibitor and anti-freeze solution to prevent damage to the pipework and system components.
- For split model systems the responsible installer should decide if anti-freeze solution is necessary for each site's conditions. Corrosion inhibitor however should always be used.

#### ■ Existing Installation (primary water circuit)

- Before connecting outdoor unit the existing heating circuit MUST be chemically cleansed to remove existing debris from the heating circuit.
- Flush the system to remove chemical cleanser.
- For all packaged model systems add a combined inhibitor and anti-freeze solution to prevent damage to the pipework and system components.
- For split model systems the responsible installer should decide if anti-freeze solution is necessary for each site's conditions. Corrosion inhibitor however should always be used.

When using chemical cleansers and inhibitors always follow manufacturer's instructions and ensure the product is appropriate for the materials used in the water circuit

### ■ Minimum amount of water required in the space heating/cooling circuit

Outdoor heat pump unit	Minimum water quantity [L]
Packaged model	
PUHZ-W50	40
PUHZ-W85	60
PUHZ-HW112	80
PUHZ-HW140	100
Split model	
PUHZ-RP35	32
PUHZ-RP50	40
PUHZ-RP60	50
PUHZ-(H)RP71	60
PUHZ-(H)RP100	80
PUHZ-(H)RP125	100
PUHZ-RP140	120
PUHZ-SW40	32
PUHZ-SW50	40
PUHZ-SW75	60
PUHZ-SW100	80
PUHZ-SW120	120
PUHZ-SHW80	60
PUHZ-SHW112	80
PUHZ-SHW140	100

<Table 4.2.1>

### ■ How to access Internal Components and Control and Electrical Box

#### <A> Opening the front panel

- Remove the two lower screws.
- Slide front panel upwards slightly and open carefully.
- Disconnect the relay connector connecting main controller cable and the control board cable.

#### <B> Opening the control and electrical box cover

- Remove the 4 screws.
- Slide the control and electrical box cover upwards slightly and remove facing panel.

#### <C> Accessing the back of the control and electrical box

The control and electrical box has a holding screw on the right and is hinged on the left hand side.

- Remove the holding screw on the control and electrical box.
- The control and electrical box can then be swung forward on the left hand hinges.

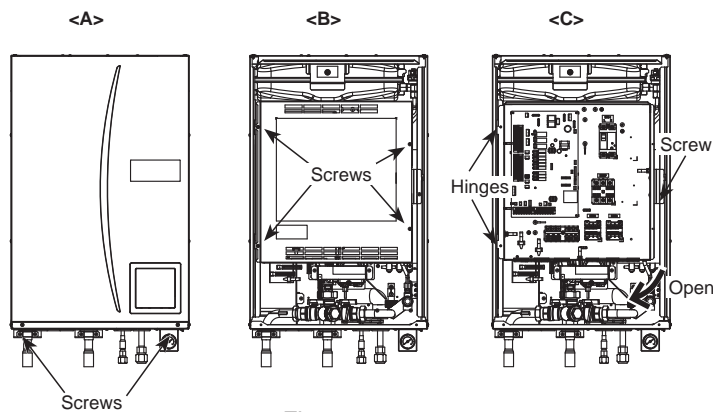

<Figure 4.2.1>

#### Note:

- Before accessing back of control and electrical box release cables from the tie straps attached to the cross-support.
- After servicing, re-secure all cables using straps provided. Reconnect main controller cable to its relay connector. Replace front panel and re-secure screws at base.

## 4 Installation

### 4.3 Water Pipe Work

**Note:** Prevent the field piping from straining the piping on the hydrobox by fixing it to a wall or applying other methods.

#### ■ Hot Water Pipework

The function of the following safety components of the hydrobox should be checked on installation for any abnormalities;

- Pressure relief valve
- Expansion vessel pre-charge (gas charge pressure)

The instruction on the following pages regarding safe discharge of hot water from Safety devices should be followed carefully.

- The pipework will become very hot, so should be insulated to prevent burns.
- When connecting pipework, ensure that no foreign objects such as debris or the like do not enter the pipe.

#### ■ Hydraulic Filter Work (ONLY EHPX series)

Install a hydraulic filter or strainer (field supply) at the water intake ("Pipe B" in Fig.3.5, also see associated schematic Fig.3.10)

#### ■ Pipework Connections

Connections to the hydrobox should be made using the 28 mm compression as appropriate. (except for ERSC series)

Do not over-tighten compression fittings as this will lead to deformation of the olive ring and potential leaks.

**Note:** To weld the pipes in the field, cool the pipes on the hydrobox using wet towel etc.

ERSC series have G1 (male) thread connections.

#### ■ Insulation of Pipework

- All exposed water pipework should be insulated to prevent unnecessary heat loss and condensation. To prevent condensate entering the hydrobox, the pipework and connections at the top of the hydrobox should be carefully insulated.
- Cold and hot water pipework should not be run close together where possible, to avoid unwanted heat transfer.
- Pipework between outdoor heat pump unit and hydrobox should be insulated with suitable pipe insulation material with a thermal conductivity of  $\leq 0.04$  W/m.K.

#### ■ Drain Pipework (ONLY ERSC series)

The drain pipe should be installed to drain condensing water in Cooling mode.

- Securely install the drain pipe to prevent leakage from the connection.
- Securely insulate the drain pipe to prevent water dripping from the field supplied drain pipe.
- Install the drain pipe at a down slope of 1/100 or more.
- Do not place the drain pipe in drain channel where sulfuric gas exists.
- After installation, check that the drain pipe drains water properly from the outlet of the pipe.

<Installation>

1. Apply polyvinyl chloride type adhesive over the shaded surfaces inside of the drain pipe and on the exterior of the drain socket as shown.
2. Insert the drain socket deeply into the drain pipe <Figure 4.3.1>.

**Note:** Securely support the field supplied drain pipe using pipe support to avoid the drain pipe falling from the drain socket.

<Checking Drainage>

- Check that the drain pipe drains water properly from the outlet of the pipe.
- Check for no leakage from the connection.

**Note:** Always check drainage at installation regardless of season.

- Remove the front panel and pour water of 1 liter into the drain pan <Figure 4.3.2>.

**Note:** Pour water slowly into the drain pan so that water does not overflow from the drain pan.

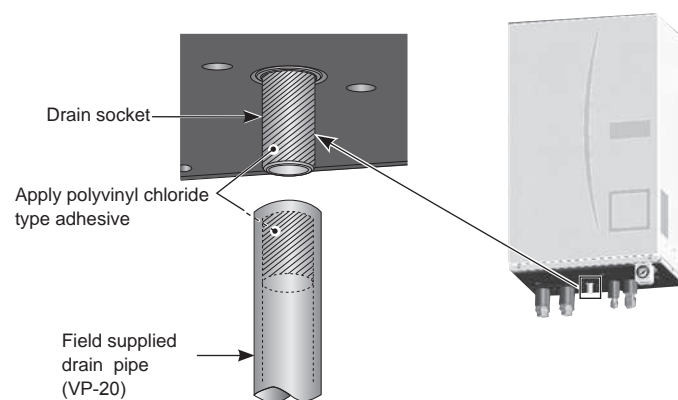

<Figure 4.3.1>

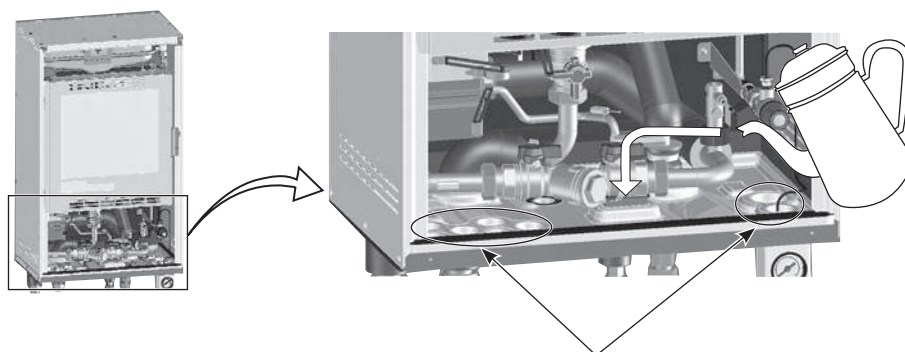

<Figure 4.3.2>

#### ■ Filling the System (Primary Circuit)

Filling

1. Check all connections including factory fitted ones are tight.
2. Insulate pipework between hydrobox and outdoor unit.
3. Thoroughly clean and flush, system of all debris. (see section 4.2 for instruction.)
4. Fill hydrobox with potable water. Fill primary heating circuit with water and suitable anti-freeze and inhibitor as necessary. **Always use a filling loop with double check valve when filling the primary circuit to avoid back flow contamination of water supply.**

- Anti-freeze should always be used for packaged model systems (see section 4.2 for instruction). It is the responsibility of the installer to decide if anti-freeze solution should be used in split model systems depending on each site's conditions. Corrosion inhibitor should be used in both split model and packaged model systems.
- When connecting metal pipes of different materials insulate the joints to prevent a corrosive reaction taking place which will damage the pipework.

5. Check for leakages. If leakage is found, retighten the screws onto the connections.
6. Pressurise system to 1 bar.
7. Release all trapped air using air vents during and following heating period.
8. Top up with water as necessary. (If pressure is below 1 bar)



## 4 Installation

### ■ Sizing Expansion Vessels

Expansion vessel volume must fit the local system water volume.

To size an expansion vessel both for the heating and cooling circuits the following formula and graph can be used.

When the necessary expansion vessel volume exceeds the volume of an built-in expansion vessel, install an additional expansion vessel so that the sum of the volumes of the expansion vessels exceeds the necessary expansion vessel volume.

\* For installation of an EHSC-\*M\*EB model, provide and install an expansion vessel in the field as the model does not come fitted with an expansion vessel.

$$V = \frac{\varepsilon \times G}{1 - \frac{P_1 + 0.098}{P_2 + 0.098}}$$

Where;

- V : Necessary expansion vessel volume [L]
- $\varepsilon$  : Water expansion coefficient
- G : Total volume of water in the system [L]
- P<sub>1</sub> : Expansion vessel setting pressure [MPa]
- P<sub>2</sub> : Max pressure during operation [MPa]

Graph to the right is for the following values

- $\varepsilon$  : at 70 °C = 0.0229
- P<sub>1</sub> : 0.1 MPa
- P<sub>2</sub> : 0.3 MPa

\*A 30% safety margin has been added.

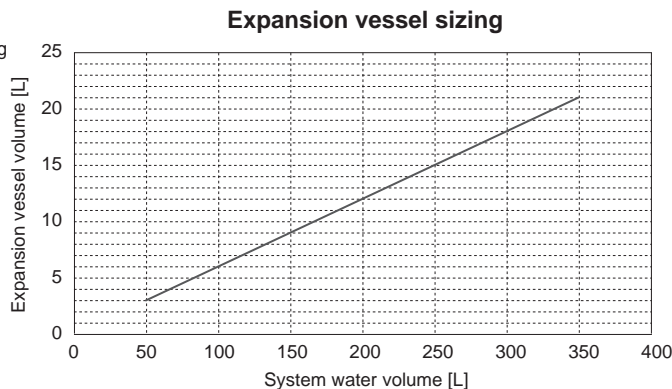

<Figure 4.3.3>

### ■ Water Circulation Pump Characteristics

Pump speed can be selected by main controller setting (see <Figure 4.3.4 - 4.3.7>).

Adjust the pump speed setting so that the flow rate in the primary circuit is appropriate for the outdoor unit installed (see Table 4.3.1). It may be necessary to add an additional pump to the system depending on the length and lift of the primary circuit.

<Second pump >

If a second pump is required for the installation please read the following carefully.

If a second pump is used in the system it can be positioned in 2 ways.

The position of the pump influences which terminal of the FTC4 the signal cable should be wired to. If the additional pump(s) have current greater than 1A please use appropriate relay. Pump signal cable can either be wired to TBO.1 1-2 or CNP1 but not both.

Option 1 (Space heating only)

If the second pump is being used for the heating circuit only then the signal cable should be wired to TBO.1 terminals 3 and 4 (OUT2). In this position the pump can be run at a different speed to the hydrobox's in-built pump.

Option 2 (Primary circuit DHW and space heating)

If the second pump is being used in the primary circuit between the hydrobox and the outdoor unit (Package system ONLY) then the signal cable should be wired to TBO.1 terminals 1 and 2 (OUT1). In this position the pump speed **MUST** match the speed of the hydrobox's in-built pump.

Note: Refer to 5.2 Connecting inputs/outputs.

Outdoor heat pump unit		Water flow rate range [L/min]
Packaged	PUHZ-W50	7.1 - 14.3
	PUHZ-W85	10.0 - 25.8
	PUHZ-HW112	14.4 - 27.7
	PUHZ-HW140	17.9 - 27.7
Split	PUHZ-RP35	7.1 - 11.8
	PUHZ-RP50	7.1 - 17.2
	PUHZ-RP60	8.6 - 20.1
	PUHZ-(H)RP71	10.2 - 22.9
	PUHZ-(H)RP100	14.4 - 27.7
	PUHZ-(H)RP125	17.9 - 27.7
	PUHZ-RP140	20.1 - 27.7
	PUHZ-SW40	7.1 - 11.8
	PUHZ-SW50	7.1 - 17.2
	PUHZ-SW75	10.2 - 22.9
	PUHZ-SW100	14.4 - 27.7
	PUHZ-SW120	20.1 - 27.7
	PUHZ-SHW80	10.2 - 22.9
	PUHZ-SHW112	14.4 - 27.7
PUHZ-SHW140	17.9 - 27.7	

<Table 4.3.1>

\* If the water flow rate is less than 7.1 L/min, the flow switch will be activated. If the water flow rate exceeds 27.7 L/min, the flow speed will be greater than 1.5 m/s, which could erode the pipes.

## Water Circulation Pump Characteristics

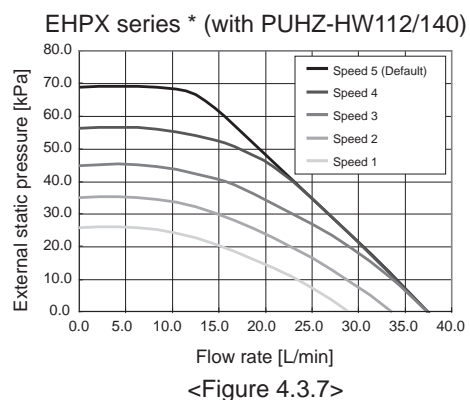
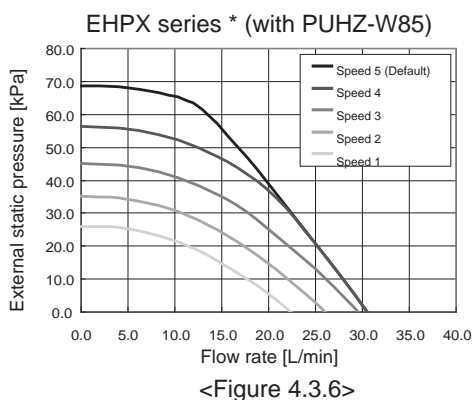
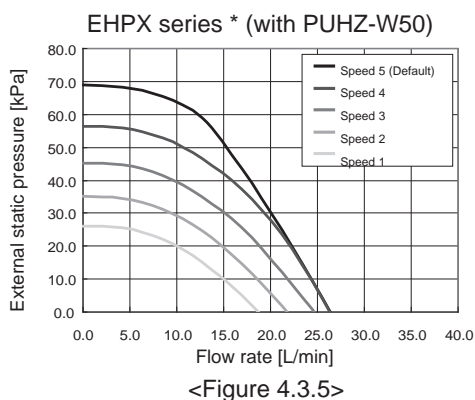
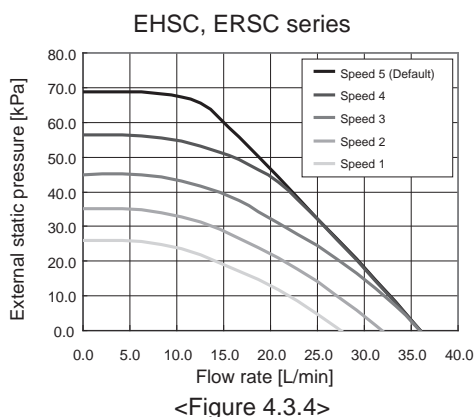

\* For installation of EHPX series, set its pump speed with a pressure drop between the hydrobox and the outdoor unit factored into the external static pressure.

### ■ Safety Device Connections

The hydrobox contains a pressure relief valve. (see <Figure 4.3.8>) The connection size is G1/2" female. The installer MUST connect appropriate discharge pipework from this valve in accordance with local and national regulations. Failure to do so will result in discharge from the pressure relief valve directly into the hydrobox and cause serious damage to the product.

All pipework used should be capable of withstanding discharge of hot water. Relief valves should NOT be used for any other purpose, and their discharges should terminate in a safe and appropriate manner in accordance with local regulation requirements.

**Note:** Beware that the manometer and the pressure relief valve are NOT strained on its capillary side and on its inlet side respectively. If a pressure relief valve is added, it is essential that no check valve or isolation valve is fitted between the hydrobox connection and the added pressure relief valve (safety matter).

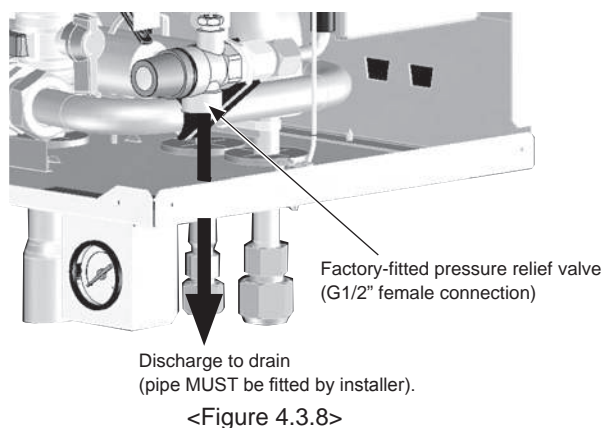

### ■ Piping diagram for 2-zone temperature control

Connect the pipe work and field supplied parts according to the relevant circuit diagram shown in Section 3. Technical Information, of this manual. For more details on wiring, refer to "5.3 Wiring for 2-zone temperature controls".

**Note:** Do not install the thermistors on the mixing tank. This could affect correct monitoring of flow and return temperatures through each zone. Install the Zone2 flow temp. thermistor (THW8) near the mixing valve.

## 4 Installation

### 4.4 Refrigerant Pipework

Refer to the outdoor unit installation manual.

Match the outer diameter of the refrigerant pipe between the outdoor unit and hydrobox with that of the refrigerant pipe on the outdoor unit.

If they do not match, connect the following adapter to the refrigerant pipe on the hydrobox.

Model name	Connected pipes diameter (mm)	Diameter A (mm)	Diameter B (mm)
PAC-SH50RJ-E	ø15.88 → ø12.7	ø15.88 (5/8 F)	ø12.7 (1/2 F)
PAC-SH30RJ-E	ø9.52 → ø6.35	ø9.52 (3/8 F)	ø6.35 (1/4 F)

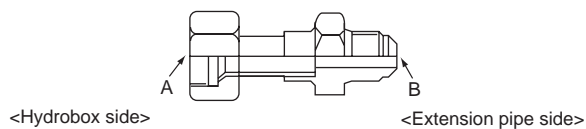

<Figure 4.3.9>

### 4.5 Electrical Connection

All electrical work should be carried out by a suitably qualified technician. Failure to comply with this could lead to electrocution, fire, and death. It will also invalidate product warranty. All wiring should be according to national wiring regulations.

Breaker abbreviation	Meaning
ECB1	Earth leakage circuit breaker for booster heater
TB1	Terminal block 1

The hydrobox can be powered in two ways.

1. Power cable is run from the outdoor unit to the hydrobox.
2. Hydrobox has independent power source.

Connections should be made to the terminals indicated in the figures to the left below depending on the phase.

Booster heater and immersion heater should be connected independently from one another to dedicated power supplies.

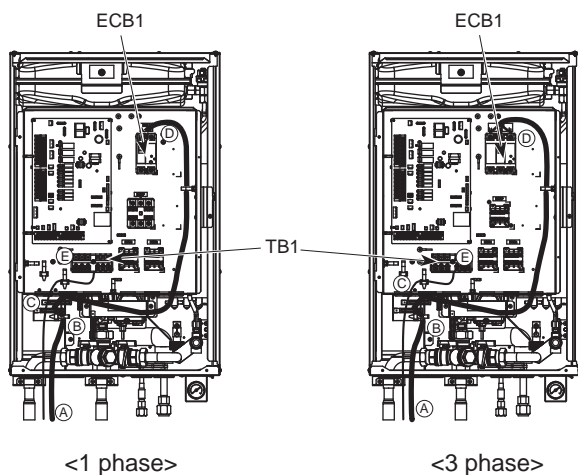

<Figure 4.5.1>

- Ⓐ Locally supplied wiring should be inserted through the inlets situated on the base of the hydrobox. (Refer to <Table 3.5-3.7>.)
- Ⓑ Wiring should be fed down the right hand side of the control and electrical box and clamped in place using clips provided.
- Ⓒ The wires should be inserted individually through the cable inlets as below.
  - ④ Output wires
  - ⑤ Signal input wires
  - ⑥ Wireless receiver (option) wire (PAR-WR51R-E)
  - ⑦ to ⑩ Power line and indoor-outdoor wire
- Ⓓ Connect the outdoor unit – hydrobox connecting cable to TB1.
- Ⓔ Connect the power cable for the booster heater to ECB1.

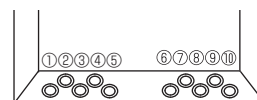

- Make sure that ECB1 is ON.

# 4 Installation

## Option 1: Hydrobox powered via outdoor unit <1 phase>

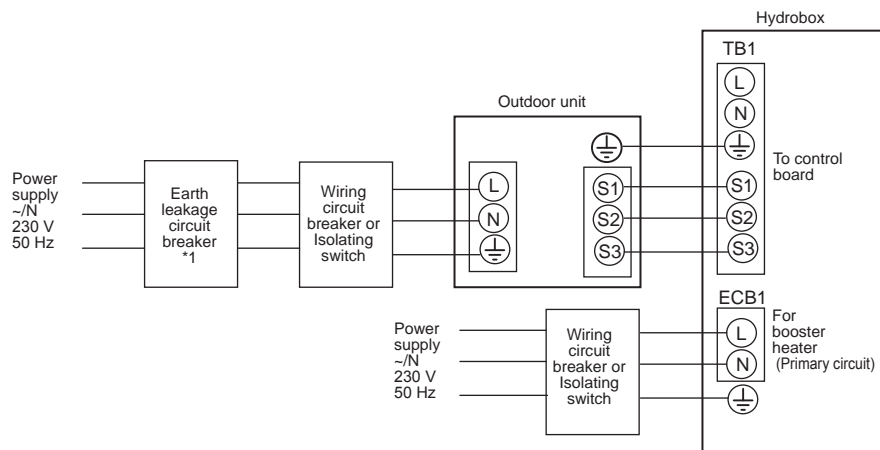

- \*1 If the installed earth leakage circuit breaker does not have an over-current protection function, install a breaker with that function along the same power line.
- \*2 Affix label A that is included with the manuals near each wiring diagram for hydrobox and outdoor units.

<Figure 4.5.5>  
Electrical connections 1 phase

Description	Power supply	Capacity	Breaker	Wiring
Booster heater (Primary circuit)	~N 230 V 50 Hz	2 kW	16 A *1	2.5 mm <sup>2</sup>
		6 kW	32 A *1	6.0 mm <sup>2</sup>

## <3 phase>

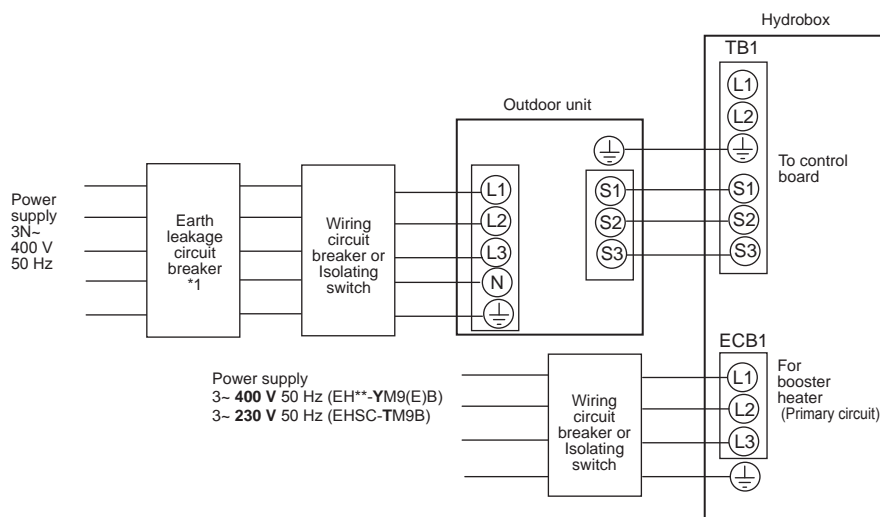

- \*1 If the installed earth leakage circuit breaker does not have an over-current protection function, install a breaker with that function along the same power line.
- \*2 Affix label A that is included with the manuals near each wiring diagram for hydrobox and outdoor units.

<Figure 4.5.6>  
Electrical connections 3 phase

Description	Power supply	Capacity	Breaker	Wiring
Booster heater (Primary circuit)	3~ 400 V 50 Hz	9 kW	16 A *1	2.5 mm <sup>2</sup>
	3~ 230 V 50 Hz	9 kW	32 A *1	6.0 mm <sup>2</sup>

Wiring No. x size (mm <sup>2</sup> )	Description	Quantity	Wiring
	Hydrobox - Outdoor unit	*2	3 × 1.5 (polar)
	Hydrobox - Outdoor unit earth	*2	1 × Min. 1.5
	Hydrobox - Outdoor unit S1 - S2	*3	230 V AC
	Hydrobox - Outdoor unit S2 - S3	*3	24 V DC

- \*1. A breaker with at least 3.0 mm contact separation in each pole shall be provided. Use earth leakage breaker (NV). The breaker shall be provided to ensure disconnection of all active phase conductors of the supply.
- \*2. Max. 45 m  
If 2.5 mm<sup>2</sup> used, Max. 50 m  
If 2.5 mm<sup>2</sup> used and S3 separated, Max. 80 m
- \*3. The values given in the table above are not always measured against the ground value.

- Notes:**
1. Wiring size must comply with the applicable local and national codes.
  2. Indoor unit/outdoor unit connecting cords shall not be lighter than polychloroprene sheathed flexible cord. (Design 60245 IEC 57)  
Indoor unit power supply cords shall not be lighter than polychloroprene sheathed flexible cord. (Design 60227 IEC 53)
  3. Install an earth longer than other cables.
  4. Please keep enough output capacity of power supply for each heater. The lack of the power supply capacity might cause chattering.

# 4 Installation

## Option2: Hydrobox powered by independent source

If the hydrobox and outdoor units have separate power supplies, the following requirements MUST be carried out:

- Change connector connections in hydrobox control and electrical box (see Figure 4.5.7).
- Turn the outdoor unit DIP switch SW8-3 to ON.
- Turn on the outdoor unit BEFORE the hydrobox.

### <1 phase>

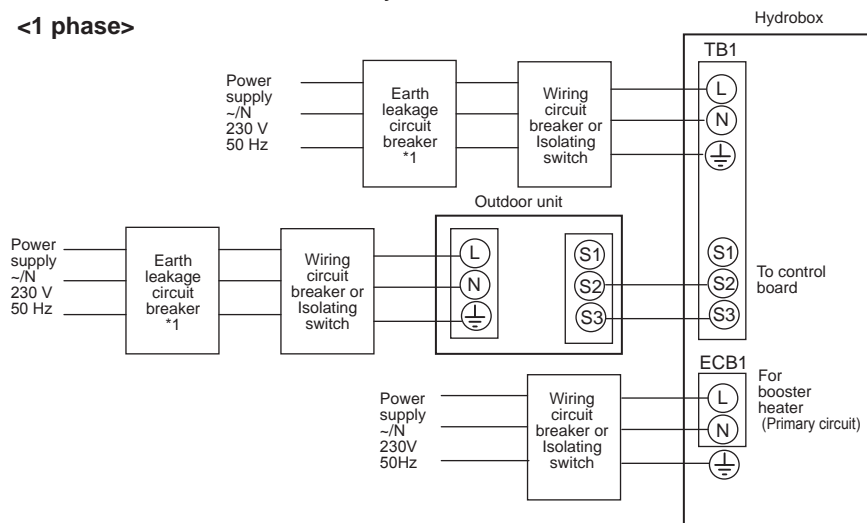

<Figure 4.5.8>  
Electrical connections 1 phase

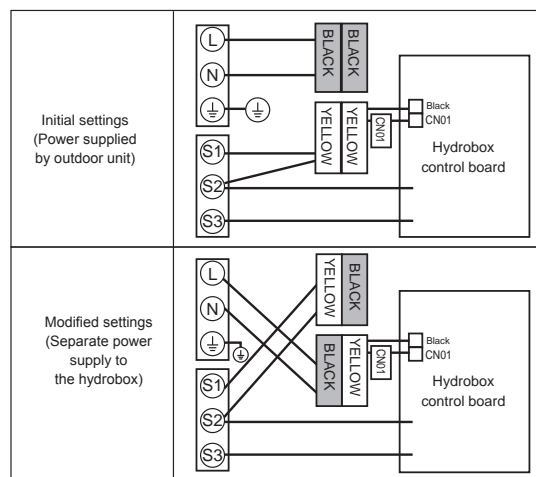

<Figure 4.5.7>

\*1 If the installed earth leakage circuit breaker does not have an over-current protection function, install a breaker with that function along the same power line.

\*2 Affix label B that is included with the manuals near each wiring diagram for hydrobox and outdoor units.

Description	Power supply	Capacity	Breaker	Wiring
Booster heater (Primary circuit)	~/N 230 V 50 Hz	2 kW	16 A *1	2.5 mm <sup>2</sup>
		6 kW	32 A *1	6.0 mm <sup>2</sup>

### <3 phase>

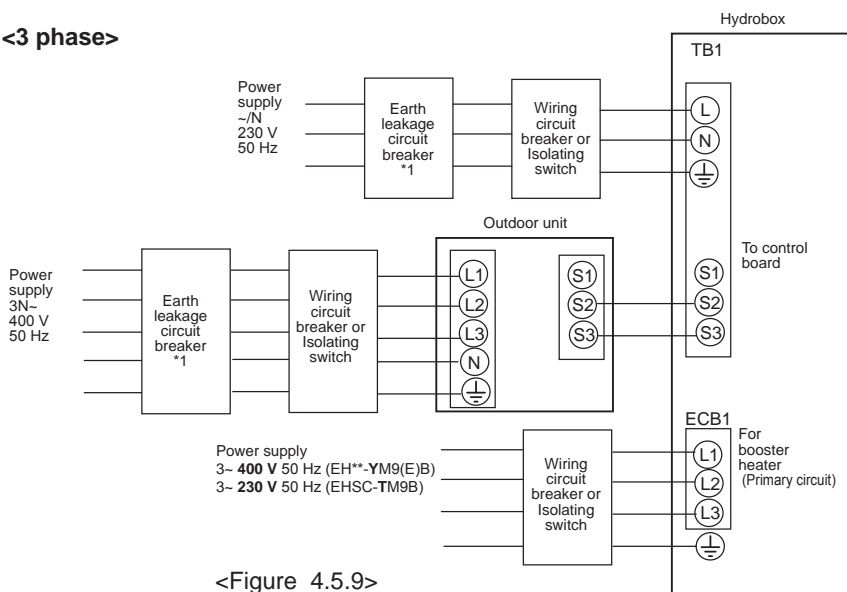

<Figure 4.5.9>  
Electrical connections 3 phase

\*1 If the installed earth leakage circuit breaker does not have an over-current protection function, install a breaker with that function along the same power line.

\*2 Affix label B that is included with the manuals near each wiring diagram for hydrobox and outdoor units.

Description	Power supply	Capacity	Breaker	Wiring
Booster heater (Primary circuit)	3~ 400 V 50 Hz	9 kW	16 A *1	2.5 mm <sup>2</sup>
		3~ 230 V 50 Hz	9 kW	32 A *1

Hydrobox power supply		~/N 230 V 50 Hz
Hydrobox input capacity		
Main switch (Breaker)	*1	16 A
Wiring No. x size (mm <sup>2</sup> )	Hydrobox power supply	2 x Min. 1.5
	Hydrobox power supply earth	1 x Min. 1.5
	Hydrobox - Outdoor unit	*2 2 x Min. 0.3
	Hydrobox - Outdoor unit earth	—
Circuit rating	Hydrobox L - N	*3 230 V AC
	Hydrobox - Outdoor unit S1 - S2	*3 —
	Hydrobox - Outdoor unit S2 - S3	*3 24 V DC

\*1. A breaker with at least 3.0 mm contact separation in each pole shall be provided. Use earth leakage breaker (NV). The breaker shall be provided to ensure disconnection of all active phase conductors of the supply.

\*2. Max. 120 m

\*3. The values given in the table above are not always measured against the ground value.

- Notes:**
1. Wiring size must comply with the applicable local and national codes.
  2. Indoor unit/outdoor unit connecting cords shall not be lighter than polychloroprene sheathed flexible cord. (Design 60245 IEC 57)  
Indoor unit power supply cords shall not be lighter than polychloroprene sheathed flexible cord. (Design 60227 IEC 53)
  3. Install an earth longer than other cables.
  4. Please keep enough output capacity of power supply for each heater. The lack of the power supply capacity might cause chattering.

## 5 System Set Up

### 5.1 Dip Switch Functions

Located on the FTC4 printed circuit board are 4 sets of small white switches known as Dip switches. The Dip switch number is printed on the circuit board next to the relevant switches. The word ON is printed on the circuit board and on the Dip switch block itself. To move the switch you will need to use a pin or the corner of a thin metal ruler or similar.

Dip switch settings are listed below in Table 5.1.1.

Make sure to turn off both indoor unit and outdoor unit power supplies before changing the switch settings.

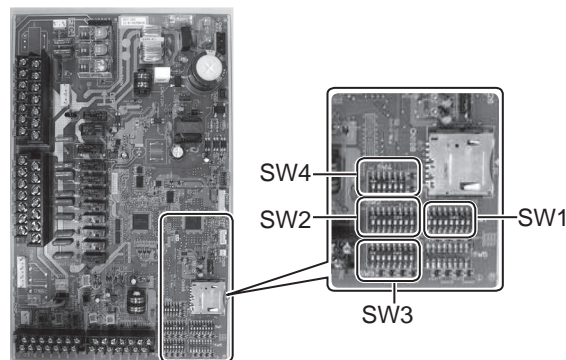

<Figure 5.1.1>

Dip switch	Function	OFF	ON	Default settings: Indoor unit model	
SW1	SW1-1 Boiler	WITHOUT Boiler	WITH Boiler	OFF	
	SW1-2 Heat pump maximum outlet water temperature	55°C	60°C	ON *1	
	SW1-3 DHW tank	WITHOUT DHW tank	WITH DHW tank	OFF	
	SW1-4 Immersion heater	WITHOUT Immersion heater	WITH Immersion heater	OFF	
	SW1-5 Booster heater	WITHOUT Booster heater	WITH Booster heater	ON	
	SW1-6 Booster heater function	For heating only	For heating and DHW	ON	
	SW1-7 Outdoor unit type	Split type	Packaged type	OFF: E*SC-*M*B ON : EHPX-*M*B	
	SW1-8 Wireless remote controller	WITHOUT Wireless remote controller	WITH Wireless remote controller	OFF	
SW2	SW2-1 Room thermostat1 input (IN1) logic change	Zone1 operation stop at thermostat short	Zone1 operation stop at thermostat open	OFF	
	SW2-2 Flow switch1 input (IN2) logic change	Failure detection at short	Failure detection at open	ON	
	SW2-3 Booster heater capacity restriction	Inactive	Active	OFF: Except E***-VM2B ON : E***-VM2B	
	SW2-4 Cooling mode function	Inactive	Active	OFF: Except ERSC-VM2B ON : ERSC-VM2B	
	SW2-5 Automatic switch to backup heat source operation (When outdoor unit stops by error)	Inactive	Active *2	OFF	
	SW2-6 Mixing tank	WITHOUT Mixing tank	WITH Mixing tank	OFF	
	SW2-7 2-zone temperature control	Inactive	Active	OFF	
	SW2-8	—	—	—	OFF
SW3	SW3-1 Room thermostat 2 input (IN6) logic change	Zone2 operation stop at thermostat short	Zone2 operation stop at thermostat open	OFF	
	SW3-2 Flow switch 2 input (IN3) logic change	Failure detection at short	Failure detection at open	OFF	
	SW3-3 Flow switch 3 input (IN7) logic change	Failure detection at short	Failure detection at open	OFF	
	SW3-4 Cooling operation in Zone2	Not in use	In use	OFF	
	SW3-5 Heating mode function *3	Inactive	Active	OFF	
	SW3-6	—	—	—	OFF
	SW3-7	—	—	—	OFF
	SW3-8	—	—	—	OFF
SW4	SW4-1 Multiple outdoor units control	Inactive	Active	OFF	
	SW4-2 Position of multiple outdoor units control *4	Slave	Master	OFF	
	SW4-3	—	—	—	OFF
	SW4-4	—	—	—	OFF
	SW4-5 Emergency mode (Heater only operation)	Normal	"Emergency mode (Heater only operation) (To be activated only when powered ON)"	OFF *5	
	SW4-6 Emergency mode (Boiler operation)	Normal	"Emergency mode (Boiler operation) (To be activated only when powered ON)"	OFF *5	

<Table 5.1.1>

- Note:**
- \*1. When the hydrobox is connected with a PUHZ-RP outdoor unit of which maximum outlet water temperature is 55°C, Dip SW1-2 must be changed to OFF.
  - \*2. OUT11 will be available. For safety reasons, this function is not available for certain errors. (In that case, system operation must be stopped and only the water circulation pump keeps running.)
  - \*3 This switch functions only when the hydrobox is connected with a PUHZ-FRP outdoor unit. When another type of outdoor unit is connected, the heating mode function is active regardless of the fact that this switch is ON or OFF.
  - \*4. SW4-2 is available only when SW4-1 is ON.
  - \*5. If emergency mode is no longer required, return the switch to OFF position.

## 5.2 Connecting inputs/outputs

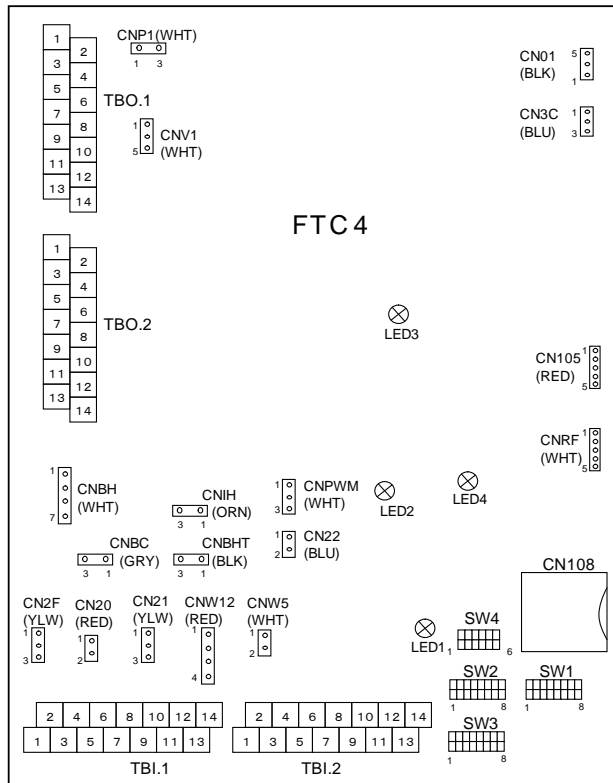

When the wires are wired to adjacent terminals use ring terminals and insulate the wires.

<Figure 5.2.1>

### Signal inputs

Name	Terminal block	Connector	Item	OFF (Open)	ON (Short)
IN1	TBI.1 1-2	—	Room thermostat 1 input	Refer to SW2-1 in <5.1 Dip Switch Functions>.	
IN2	TBI.1 3-4	CN2F	Flow switch 1 input	Refer to SW2-2 in <5.1 Dip Switch Functions>.	
IN3	TBI.1 5-6	—	Flow switch 2 input (Zone1)	Refer to SW3-2 in <5.1 Dip Switch Functions>.	
IN4	TBI.1 7-8	—	Demand control input	Normal	Heat source OFF/ Boiler operation *2
IN5	TBI.1 9-10	—	Outdoor thermostat input (*1)	Standard operation	Heater operation/ Boiler operation *2
IN6	TBI.1 11-12	—	Room thermostat 2 input	Refer to SW3-1 in <5.1 Dip Switch Functions>.	
IN7	TBI.1 13-14	—	Flow switch 3 input (Zone2)	Refer to SW3-3 in <5.1 Dip Switch Functions>.	

\*1. If using outdoor thermostat for controlling operation of heaters, the lifetime of the heaters and related parts may be reduced.

\*2. To turn on the boiler operation, use the main controller to select "Boiler" in "External input setting" screen in the service menu.

### Wiring specification and field supply parts

Item	Name	Model and specifications
Signal input function	Signal input wire	Use sheathed vinyl coated cord or cable. Max. 10 m Wire type: CV, CVS or equivalent Wire size: Stranded wire 0.5 mm <sup>2</sup> to 1.25 mm <sup>2</sup> Solid wire: ø0.65 mm to ø1.2 mm
	Switch	Non-voltage "a" contact signals Remote switch: minimum applicable load 12V DC, 0.1mA

### Thermistor inputs

Name	Terminal block	Connector	Item	Optional part model
TH1	—	CN20	Thermistor (Room temp.) (Option)*1	PAC-SE41TS-E
TH2	—	CN21	Thermistor (Ref. liquid temp.)	—
THW1	—	CNW12 1-2	Thermistor (Flow water temp.)	—
THW2	—	CNW12 3-4	Thermistor (Return water temp.)	—
THW5	—	CNW5	Thermistor (DHW tank water temp.) (Option)*1	PAC-TH011TK-E
THW6	TBI.2 7-8	—	Thermistor (Zone1 flow water temp.) (Option)*1	PAC-TH011-E
THW7	TBI.2 9-10	—	Thermistor (Zone1 return water temp.) (Option)*1	PAC-TH011-E
THW8	TBI.2 1-2	—	Thermistor (Zone2 flow water temp.) (Option)*1	PAC-TH011-E
THW9	TBI.2 11-12	—	Thermistor (Zone2 return water temp.) (Option)*1	PAC-TH011-E
THWB1	TBI.2 3-4	—	Thermistor (Boiler flow water temp.) (Option)*1	PAC-TH011HT-E
THWB2	TBI.2 5-6	—	Thermistor (Boiler return water temp.) (Option)*1	PAC-TH011HT-E

Do not splice the wiring to extend or shorten it, or this could affect correct monitoring of each temperature.

If the wiring is too long, bundle it with a strap to adjust the length.

\*1. The maximum length of the thermistor wiring is 5 m.

When the wires are wired to adjacent terminals, use ring terminals and insulate the wires.

# 5 System Set Up

## ■ Outputs

Name	Terminal block	Connector	Item	OFF	ON	Signal/Max current	Max. total current
OUT1	TBO.1 3-4	CNP1	Water circulation pump 1 output (Space heating & DHW)	OFF	ON	230V AC 1.0 A Max	3.0 A (a)
OUT2	TBO.1 5-6	—	Water circulation pump 2 output (Space heating for Zone1)	OFF	ON	230V AC 1.0 A Max	
OUT3	TBO.1 7-8	—	Water circulation pump 3 output (Space heating for Zone2)	OFF	ON	230V AC 1.0 A Max	
OUT4	TBO.1 9-11	CNV1	3-way valve (2-way valve 1) output	Heating	DHW	230V AC 0.1 A Max	3.0 A (b)
OUT5	TBO.1 12-13	—	Mixing valve output	Stop	Close	230V AC 0.1 A Max	
	TBO.1 13-14			Stop	Open		
OUT6	—	CNBH 1-3	Booster heater 1 output	OFF	ON	230V AC 0.5 A Max (Relay)	
OUT7	—	CNBH 5-7	Booster heater 2 output	OFF	ON	230V AC 0.5 A Max (Relay)	
OUT8	TBO.2 11-12	—	Booster heater 2+ output	OFF	ON	230V AC 0.5 A Max (Relay)	
OUT9	TBO.2 9-10	CNIH	Immersion heater output	OFF	ON	230V AC 0.5 A Max (Relay)	
OUT11	TBO.2 1-2	—	Error output	Normal	Error	230V AC 0.5 A Max	
OUT12	TBO.2 3-4	—	Defrost output	Normal	Defrost	230V AC 0.5 A Max	
OUT13	TBO.2 7-8	—	2-way valve 2 output	DHW	Heating	230V AC 0.1 A Max	
OUT10	TBO.1 1-2	—	Boiler output	OFF	ON	non-voltage contact • 220 - 240V AC (30V DC) 0.5A or less • 10 mA 5V DC or more	—

Do not connect to the terminals that are indicated as “—” in the “Terminal block” field.

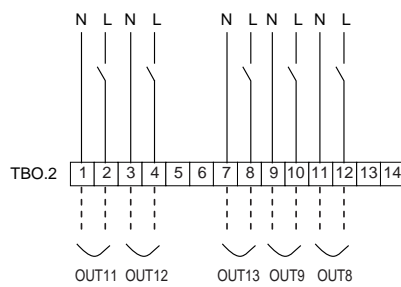
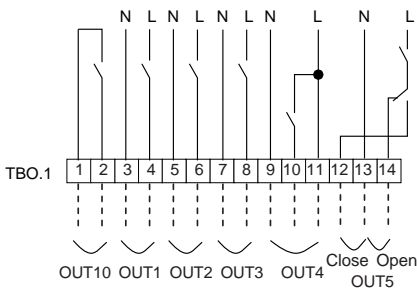

### Wiring specification and field supply parts

Item	Name	Model and specifications
External output function	Outputs wire	Use sheathed vinyl coated cord or cable. Max. 30 m Wire type: CV, CVS or equivalent Wire size: Stranded wire 0.5 mm <sup>2</sup> to 1.25 mm <sup>2</sup> Solid wire: ø0.65 mm to ø1.2 mm

### Note:

- When the hydrobox is powered via outdoor unit, the maximum grand total current of (a)+(b) is 3.0 A.
- Do not connect multiple water circulation pumps directly to each output (OUT1, OUT2, and OUT3). In such a case, connect them via (a) relay(s).
- Do not connect water circulation pumps to both TBO.1 3-4 and CNP1 at the same time.
- Connect an appropriate surge absorber to OUT10 (TBO.1 1-2) depending on the load at site.

## 5.3 Wiring for 2-zone temperature control

- Water circulation pump 2 (Zone1 water circulation pump) / Water circulation pump 3 (Zone2 water circulation pump)  
Electrically wire water circulation pumps 2 and 3 to the appropriate output terminals. (Refer to “Outputs” in 5.2.)

- Flow switch 2 (Zone1 flow switch) / Flow switch 3 (Zone2 flow switch)

Connect flow switches 2 and 3 to the appropriate terminals. (Refer to “Signal inputs” in 5.2.)

Set dip switches 3-2 and 3-3 according to the functions of individual flow switches 2 and 3. (Refer to “Dip switch functions” in 5.1.)

- Thermistor

Connect the thermistor to monitor the Zone1 flow temp. to the THW6 (TBI. 2-7 and 2-8) terminals.

Connect the thermistor to monitor the Zone1 return temp. to the THW7 (TBI. 2-9 and 2-10) terminals.

Connect the thermistor to monitor the Zone2 flow temp. to the THW8 (TBI. 2-1 and 2-2) terminals.

Connect the thermistor to monitor the Zone2 return temp. to the THW9 (TBI. 2-11 and 2-12) terminals.

The maximum length of the thermistor wiring is 5 m. Do not splice the wiring to extend or shorten it, or this could affect correct monitoring of each hot water temperature through zones.

If the wiring is too long, bundle it with a strap to adjust the length.

- Motorized mixing valve

Connect three wires coming from the motorized mixing valve to the appropriate terminals referring to “Outputs” in 5.2.

**Note:** Connect the signal line to open Port A (hot water inlet port) to TBO. 1-14 (Open), the signal line to open Port B (cold water inlet port) to TBO. 1-12 (Close), and the neutral terminal wire to TBO. 1-13 (N).

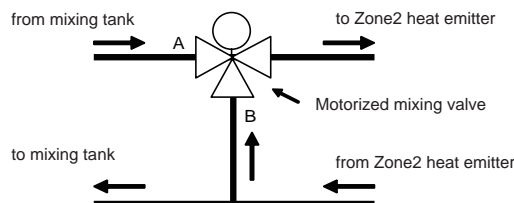
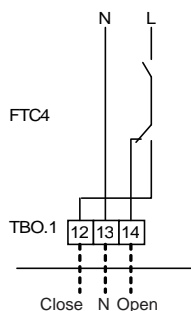



## 5 System Set Up

### 5.4 Installation procedure for DHW tank

**Note:**

- Be aware that the respective DHW operations are greatly effected by the selections of the components such as tank, immersion heater, or the like.
- Follow your local regulations to perform system configuration.

1. To enable switching of the water circulation circuit between the DHW mode and the heating mode, install a 3-way valve (field supply). The 3-way valve and the DHW tank should be positioned as shown in the system diagram on the page 9, Figure 3.7 or 3.8 as applicable.

The use of two 2-way valves can perform the same function as a 3-way valve.

2. Install the optional thermistor THW5 (optional part PAC-TH011TK-E) on the DHW tank.

It is recommended to position the thermistor at the mid point of the DHW tank capacity. Insulate thermistor from ambient air. Especially for double (insulated) tank, thermistor should be attached to the inner side (to detect the water temperature).

3. Connect the thermistor lead to the CNW5 connector on the FTC4.

If the thermistor lead is too long bundle it with a strap to adjust the length.

4. The output terminals for the 3-way valve is TBO.1 9-11 (OUT4).

The TBO.1 9-11 terminals on the FTC4 are shown in the wiring diagram on Page 22.

Choose the terminals that the 3-way valve is connected to between TBO.1 9-10, or TBO.1 9-11, according to the rated voltage.

When the rated current of the 3-way valve exceeds 0.1A, be sure to use a relay with maximum voltage and current ratings of 230V AC / 0.1A when connecting to the FTC4. Do not directly connect the 3-way valve cable to the FTC4. Connect the relay cable to the TBO.1 9-10 terminals.

3-way valve must be of SPST type. SPDT type can NOT be used.

For systems using 2-way valves instead of a 3-way valve please read the following;

- Power supply: 230V AC
- Current: 0.1A Max (If over 0.1A you must use a relay)
- Type: Normally closed

	Installation position	Electrical connection terminal block	Output signal		
			Heating	DHW	System OFF
2-way valve1	DHW	TBO.1 9-10	OFF (closed)	ON (open)	OFF (closed)
2-way valve2	Heating	TBO.2 7-8	ON (open)	OFF (closed)	OFF (closed)

Note: Should the 2-way valve become blocked the water circulation will stop.

A by-pass valve or circuit should be installed between pump and 2-way valve for safety.

The TBO.2 7-8 terminals on the FTC4 are shown in the wiring diagram.

The 2-way valve (field supply) should be installed according to the instructions supplied with it. Follow 2-way valve's manufacturer's instructions as to whether to connect an earth cable or not.

- For the 2-way valve, choose the one that slowly opens and shuts off to prevent water hammer sound.
- Choose the 2-way valve equipped with manual override, which is necessary for topping up or draining of water.

5. Turn the DIP SW1-3 on the FTC4 to ON.

6. When using an immersion heater (field supply), connect a contact relay cable for the immersion heater to TBO.2 9-10 (OUT9), and turn the Dip SW1-4 to ON. Do NOT directly connect the power cable to the FTC4.

**Note:**

- When an immersion heater is installed, select appropriate breaker capacity and a cable with appropriate diameter on the basis of heater output.
- When wiring an immersion heater in the field, always install an earth leakage breaker to prevent accidental electric shock.

#### Specification of 2-way valve (field supply)

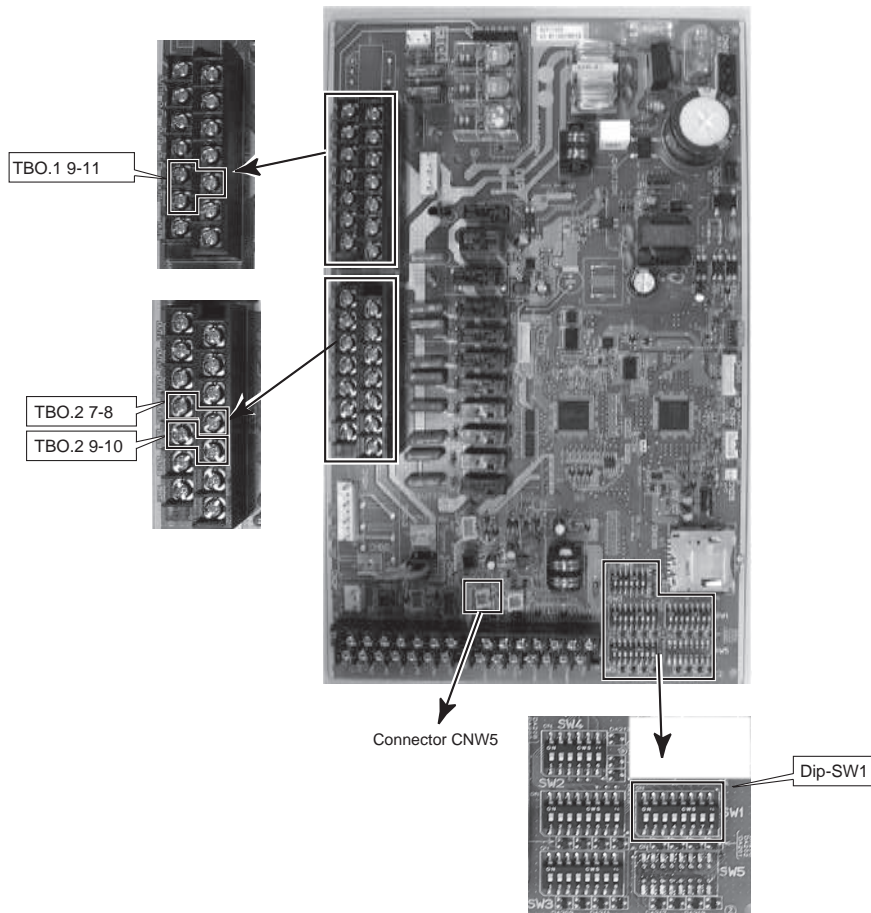

- ⚠ WARNING: When connecting DHW tank**
- (1) Attach the optional thermistor THW5 (PAC-TH011TK-E).
  - (2) Always use earth leakage breaker when connecting immersion heater.
  - (3) When installing an immersion heater, be sure that the immersion heater has a built-in direct cut-off thermostat.
  - (4) Connect a pressure relief valve on the sanitary water side.
  - (5) It is essential that no check valve or isolating valve is fitted between the hydrobox and the pressure relief valve.

# 5 System Set Up

## Recommended DHW system

Where system involves a DHW tank:

DHW tank	Immersion heater	Booster heater	BH function	System diagram	Thermistor
Present	Absent	Present	For space heating/ cooling and DHW		THW1: Flow water temp. THW2: Return water temp. THW5: Tank water temp. (optional part PAC-TH011TK-E)
Present	Present	Present	For space heating/ cooling and DHW		THW1: Flow water temp. THW2: Return water temp. THW5: Tank water temp. (optional part PAC-TH011TK-E)

\*The use of two 2-way valves can perform same function as a 3-way valve.

# 5 System Set Up

## 5.5 Remote Controller Options

The hydrobox comes factory fitted with a main controller. This incorporates a thermistor for temperature monitoring and a graphical user interface to enable set-up, view current status and input scheduling functions. The main controller is also used for servicing purposes. This facility is accessed via password protected service menus.

To provide the best efficiency Mitsubishi Electric recommends using automatic adaptation function based on room temperature. To use this function a room thermistor needs to be present in a main living area. This can be done in a number of ways the most convenient are detailed below.

**Refer to heating section of this manual for instructions on how to set compensation curve, flow temp or room temp (Auto adaptation).**

**For instructions on how to set the thermistor input for the FTC4 please refer to Initial settings section.**

The factory setting for space heating mode is set to Room temp. (auto adaptation). If there is no room sensor present in the system, this setting must be changed to either Compensation curve mode or Flow temp mode.

**Note: Auto-adaptation is not available in Cooling mode.**

### ■ 1-zone temperature control

#### Control option A

This option features the main controller and the Mitsubishi Electric wireless remote controller. The wireless remote controller is used to monitor room temperature and can be used to make changes to the space heating settings, boost DHW (\*1) and switch to holiday mode without having to directly use the main controller.

If more than one wireless remote controller is used, the most recently requested temperature setting will commonly be applied to all rooms by the central control system regardless of which wireless remote controller was used. No hierarchy exists across these remote controllers.

Wire the wireless receiver to FTC4 referring to the wireless remote controller instruction manual. **Turn DIP SW1-8 to ON.** Before operation configure the wireless remote controller to transmit and receive data referring to the wireless remote controller installation manual.)

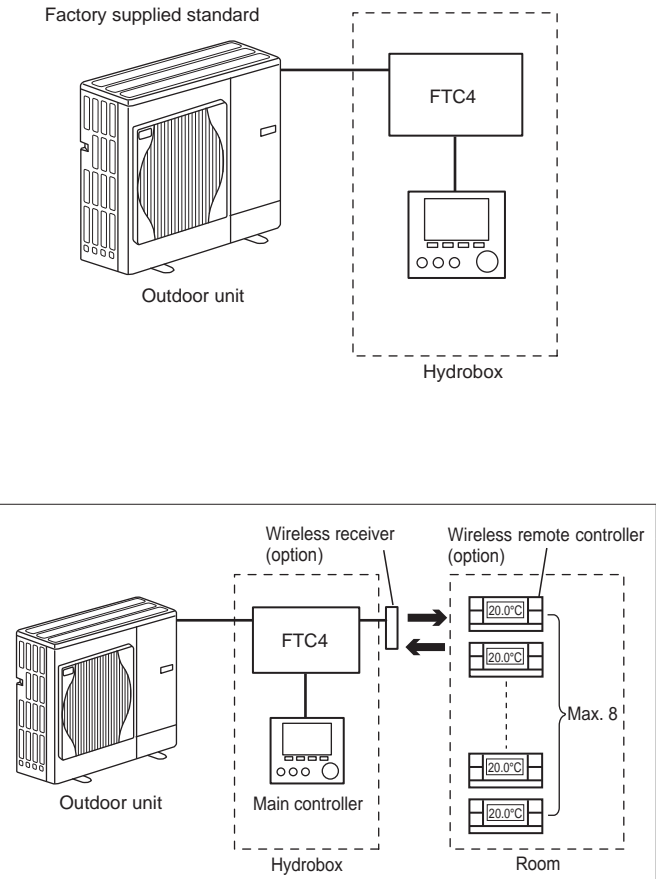

#### Control option B

This option features the main controller and the Mitsubishi Electric thermistor wired to FTC4. The thermistor is used to monitor room temperature but can not make any changes in control operation. Any changes to DHW (\*1) must be made using the main controller mounted on the hydrobox.

Wire the thermistor to the TH1 connector on FTC4. The number of room temperature thermistors that can be connected to FTC4 is always one.

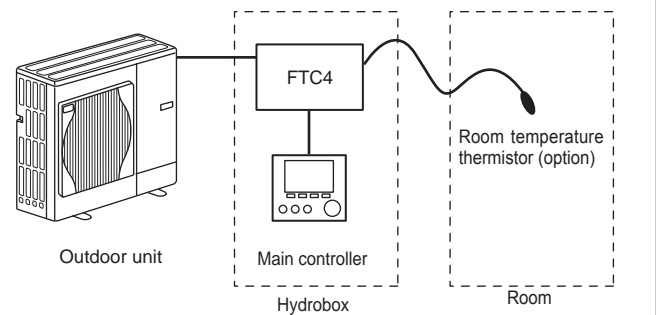

#### Control option C

This option features the main controller being removed from the hydrobox and situated in a different room. A thermistor built in the main controller can be used for monitoring the room temperature for Auto Adaptation function whilst keeping all its features of the main controller available.

The main controller and FTC4 are connected by a 2-core, 0.3 mm<sup>2</sup>, non-polar cable (field supply) with a maximum length of 500 m.

To use the sensor in the main controller the main controller should come off from the hydrobox. Otherwise it will detect the temperature of the hydrobox instead of room temperature. This will affect the output of the space heating.

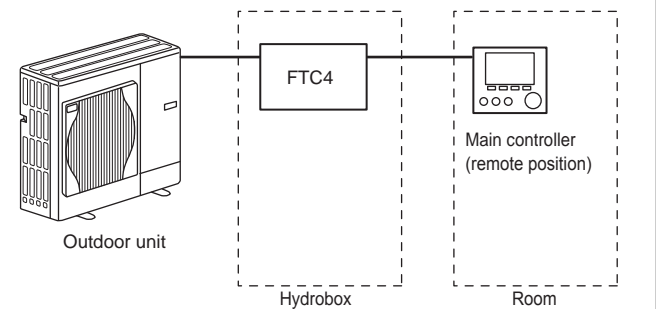

#### Control option D (Flow temp. or compensation curve only)

This option features the main controller and a locally supplied thermostat wired to FTC4. The thermostat is used to set the maximum temperature for heating room. Any changes to DHW (\*1) must be made using main controller mounted on the hydrobox.

The thermostat is wired to IN1 in TBI.1 on FTC4. The number of thermostats that can be connected to FTC4 is always one.

★ The wireless remote controller can be also used as a thermostat.

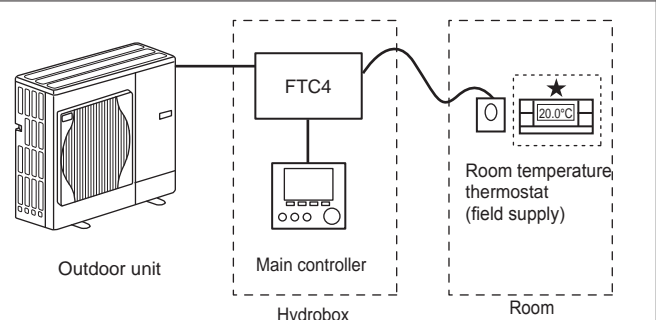

\*1 If applicable

# 5 System Set Up

## 2-zone temperature control

### Control option A

This option features the main controller, the Mitsubishi Electric wireless remote controller and a locally supplied thermostat.

The wireless remote controller is used to monitor the Zone1 room temperature and the thermostat is used to monitor the Zone2 room temperature.

The thermostat can be also allocated to Zone1 and the wireless remote controller to Zone2.

The wireless remote controller can be also used to make changes to the space heating settings, boost DHW (\*1) and switch to holiday mode without having to use the main controller.

If more than one wireless remote controller is used, the last temperature setting adjustment/demand will be applied to ALL rooms in same zone.

Wire the wireless receiver to FTC4 referring to the wireless remote controller instruction manual. Turn DIP SW1-8 to ON. Before operation configure the wireless remote controller to transmit and receive data referring to the wireless remote controller installation manual.)

The thermostat is used to set the maximum temperature for heating Zone2 room. The thermostat is wired to IN6 on FTC4. (If the thermostat is allocated to Zone1, it is wired to IN1 on TBI.1.) (Refer to 5.2.)

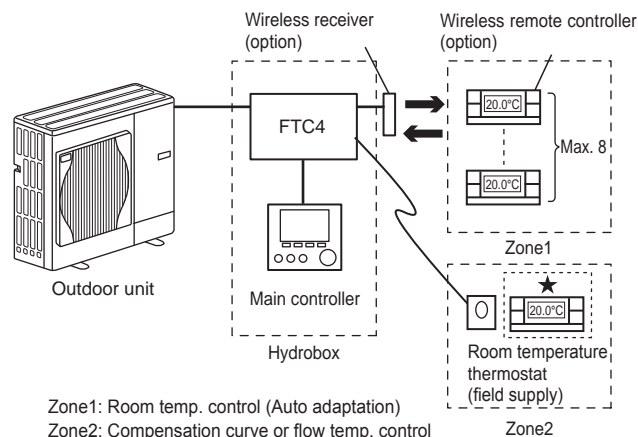

### Control option B

This option features the main controller, the Mitsubishi Electric thermistor and a locally supplied thermostat that are wired to FTC4.

The thermistor is used to monitor the Zone1 room temperature and the thermostat is used to control the Zone2 room temperature.

The thermostat can be also allocated to Zone1 and the thermistor to Zone2.

The thermistor can not make any changes in control operation. Any changes to DHW (\*1) must be made using the main controller mounted on the hydrobox.

Wire the thermistor to the TH1 connector on FTC4.

The number of room temperature thermistors that can be connected to FTC4 is always one.

The thermostat is used to set the maximum temperature for heating Zone2 room.

The thermostat is wired to IN6 on FTC4. (If the thermostat is allocated to Zone1, wire it to IN1 on TBI.1.) (Refer to 5.2.)

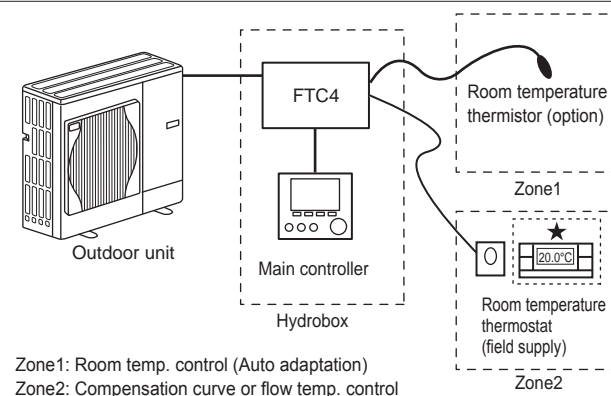

### Control option C

This option features the main controller (with in-built thermistor) that is removed from the hydrobox to monitor the Zone1 room temperature and a locally supplied thermostat to monitor the Zone2 room temperature.

The thermostat can be also allocated to Zone1 and the thermistor to Zone2.

A thermistor built into the main controller can be used for monitoring the room temperature for Auto Adaptation function whilst keeping all its features of the main controller available.

The main controller and FTC4 are connected by a 2-core, 0.3 mm<sup>2</sup>, non-polar cable (field supply) with a maximum length of 500 m.

To use the sensor in the main controller the main controller should be detached from the hydrobox. Otherwise it will detect the temperature of the hydrobox instead of room temperature. This will affect the output of the space heating.

The thermostat is used to set the maximum temperature for heating Zone2 room.

The thermostat is wired to IN6 on FTC4. (If the thermostat is allocated to Zone1, wire it to IN1 on TBI.1.) (Refer to 5.2.)

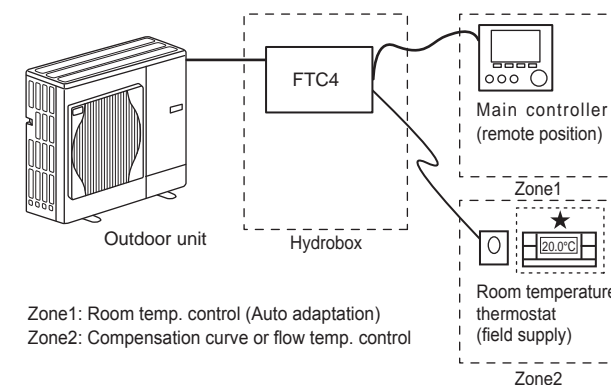

### Control option D

This option features the locally supplied thermostats wired to FTC4. The thermostats are individually allocated to Zone1 and Zone2. The thermostats are used to set each maximum temperature for heating Zone1 and Zone2 rooms. Any changes to DHW (\*1) must be made using the main controller mounted on the hydrobox.

The thermostat for Zone1 is wired to IN1 in TBI.1 on FTC4.

The thermostat for Zone2 is wired to IN6 in TBI.1 on FTC4.

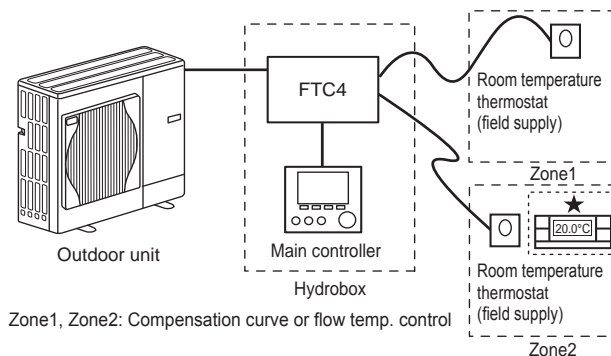

\*1 If applicable

\*2 For the options above, the sensor types can be exchanged between Zone1 and Zone2. (e.g. Wireless remote controller in Zone1 and Room temp thermostat in Zone2 can be changed to Room temp thermostat and wireless remote controller, respectively).

★ The wireless remote controller can be also used as a thermostat.

## 5 System Set Up

### Remote Installation of Main Controller

The following instructions are related to a system controlled as in Control option C.

#### <Removing the main controller from the hydrobox>

1. Open front panel of hydrobox. (See section 4.2.)
2. Remove the four screws from the metal back plate of main controller using a screwdriver. (Figure 5.5.1)
3. Lift off the metal back plate.
4. Gently pull apart the clips holding the main controller in place. Be careful not to use too much force as this may break the holding clips.
5. Lift out the main controller from the front panel of the hydrobox.

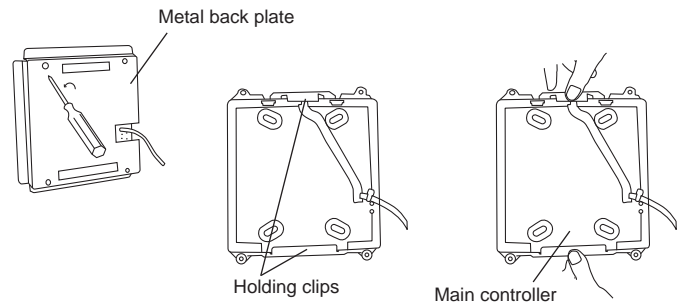

<Figure 5.5.1>  
Removing main controller

6. Separate the back and front plates using a flat head screwdriver as shown in Figure 5.5.2.

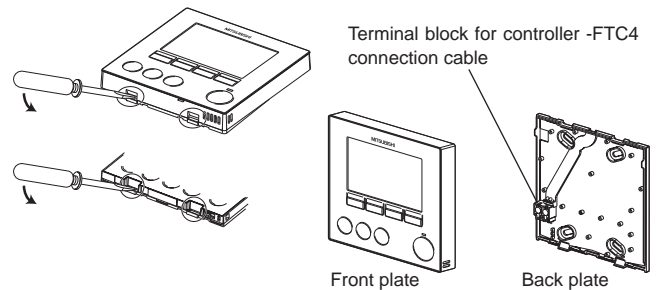

<Figure 5.5.2>  
Opening the main controller

7. Fix the 2 core cable from the FTC4 into the terminal. Ensure the wires make good contact and are securely screwed into the terminal block. (Figure 5.5.3)
8. The inner core wires should not be visible from the outside of the back plate. (Figure 5.5.3)
9. The sheathed cable should be pressed into the sunken channel so it is flush with the back plate.
10. Once the connection cable is in place screw the back plate to the wall using screws (field supply) suitable for use on the chosen wall. (Figure 5.5.4)
11. Finally replace the front plate.

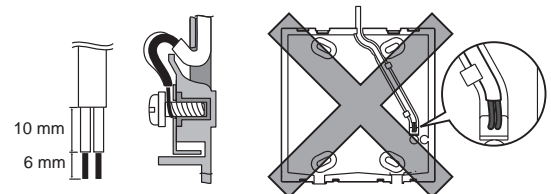

<Figure 5.5.3>  
Securing the connection cable

#### Note:

Wiring for main controller cable shall be (5cm or more) apart from power source wiring so that it is not influenced by electrical noise from power source wiring. (Do NOT insert main controller cable and power source wiring in the same conduit.)

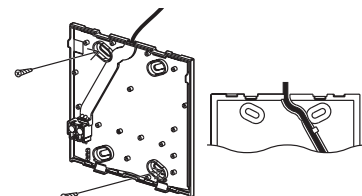

<Figure 5.5.4>  
Securing the back plate to the wall

## 5 System Set Up

### 5.6 Using SD memory card

The hydrobox is equipped with an SD memory card interface in FTC4. Using an SD memory card can simplify main controller settings and can store operating logs. \*1

- (a) For insertion, push on the SD memory card until it clicks into place.  
 (b) For ejection, push on the SD memory card until it clicks.

**Note:** To avoid cutting fingers, do not touch sharp edges of the SD memory card connector (CN108) on the FTC4 control board.

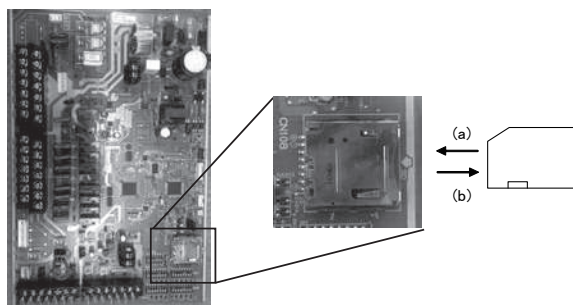

#### <Handling precautions>

- (1) Use an SD memory card that complies with the SD standards. Check that the SD memory card has a logo on it of those shown to the right.
- (2) SD memory cards to the SD standards include SD, SDHC, miniSD, micro SD, and microSDHC memory cards. The capacities are available up to 32 GB. Choose that with a maximum allowable temperature of 55°C.
- (3) When the SD memory card is a miniSD, miniSDHC, microSD, or micro SDHC memory card, use an SD memory card converter adapter.
- (4) Before writing to the SD memory card, release the write-protect switch.



- (5) Before inserting or ejecting an SD memory card, make sure to power off the system. If an SD memory card is inserted or ejected with the system powered on, the stored data could be corrupted or the SD memory card be damaged. \*An SD memory card is live for a whilst after the system is powered off. Before insertion or ejection wait until the LED lamps on the FTC4 control board are all off.
- (6) The read and write operations have been verified using the following SD memory cards, however, these operations are not always guaranteed as the specifications of these SD memory cards could change.

Manufacturer	Model	Tested in
Verbatim	#44015 0912-61	Mar. 2012
SanDisk	SDSDB-002G-B35	Oct. 2011
Panasonic	RP-SDP04GE1K	Oct. 2011
Arvato	2GB PS8032 TSB 24nm MLC	Jun. 2012

Before using a new SD memory card (including the card that comes with the unit), always check that the SD memory card can be safely read and written to by the FTC4 controller.

#### <How to check read and write operations>

- a) Check for correct wiring of power supply to the system. For more details, refer to section 4.5.  
 (Do not power on the system at this point.)
  - b) Insert an SD memory card.
  - c) Power on the system.
  - d) The LED4 lamp lights if the read and write operations are successfully completed. If the LED4 lamp continues blinking or does not light, the SD memory card cannot be read or written to by the FTC4 controller.
- (7) Make sure to follow the instruction and the requirement of the SD memory card's manufacturer.
  - (8) Format the SD memory card if determined unreadable in step (6). This could make it readable.  
 Download an SD card formatter from the following site.  
 SD Association homepage: <https://www.sdcard.org/home/>
  - (9) FTC4 supports FAT file system but not NTFS file system.
  - (10) Mitsubishi Electric is not liable for any damages, in whole or in part, including failure of writing to an SD memory card, and corruption and loss of the saved data, or the like. Back up saved data as necessary.
  - (11) Do not touch any electronic parts on the FTC4 control board when inserting or ejecting an SD memory card, or else the control board could fail.

#### Logos



#### Capacities

2 GB to 32 GB \*2

#### SD speed classes

All

- The SD Logo is a trademark of SD-3C, LLC.  
 The miniSD logo is a trademark of SD-3C, LLC.  
 The microSD logo is a trademark of SD-3C, LLC.

\*1 To edit main controller settings or to check operating data, an Ecodan service tool (for use with PC) is required.

\*2 A 2-GB SD memory card stores up to 30 days of operation logs.

# 5 System Set Up

## 5.7 Main Controller

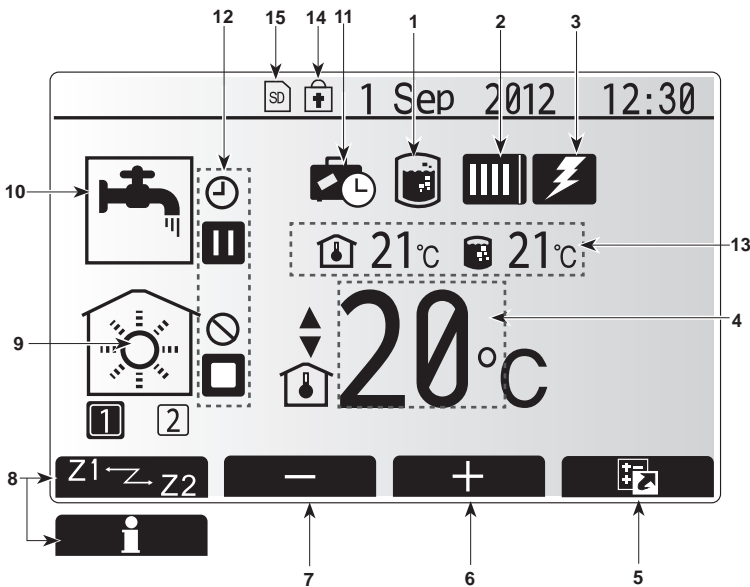
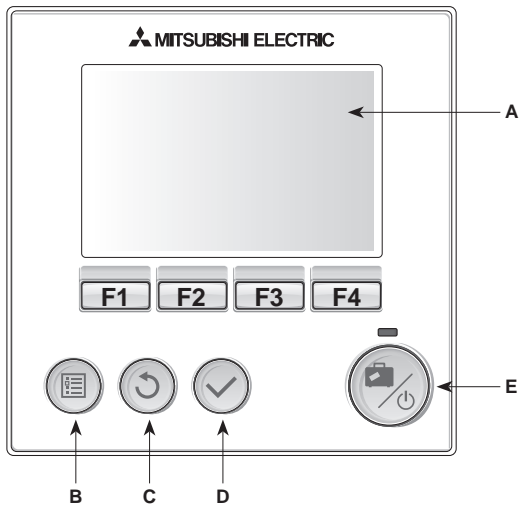

### <Main controller parts>

Letter	Name	Function
A	Screen	Screen in which all information is displayed
B	Menu	Access to system settings for initial set up and modifications.
C	Back	Return to previous menu.
D	Confirm	Used to select or save. (Enter key)
E	Power/Holiday	If system is switched off pressing once will turn system on. Pressing again when system is switched on will enable Holiday Mode. Holding the button down for 3 secs will turn the system off. (*1)
F1-4	Function keys	Used to scroll through menu and adjust settings. Function is determined by the menu screen visible on screen A.

\*1

When the system is switched off or the power supply is disconnected, the hydrobox protection functions (e.g. freeze stat. function) will NOT operate. Please beware that without these safety functions enabled the hydrobox may potentially become exposed to damage.

### <Main screen icons>

	Icon	Description
1	Legionella prevention	When this icon is displayed 'Legionella prevention mode' is active.
2	Heat pump	'Heat pump' is running.
		Defrosting.
		Emergency heating.
3	Electric heater	When this icon is displayed the 'Electric heaters' (booster or immersion heater) are in use.
4	Target temperature	Target flow temperature
		Target room temperature
		Compensation curve
5	OPTION	Pressing the function button below this icon will display the quick view menu.
6	+	Increase desired temperature.
7	-	Decrease desired temperature.
8	Z1 Z2	Pressing the function button below this icon switches between Zone1 and Zone2.
	Information	Pressing the function button below this icon displays the information screen.
9	Space heating (cooling) mode	Heating mode Zone1 or Zone2
		Cooling mode
10	DHW mode	Normal or ECO mode
11	Holiday mode	When this icon is displayed 'Holiday mode' activated.
12	Timer	Timer
		Prohibited
		Stand-by
		Stop
		Operating
13	Current temperature	Current room temperature
		Current water temperature of DHW tank
14	The Menu button is locked or the switching of the operation modes between DHW and Heating operations are disabled in the Option screen.	
15	SD memory card is inserted. Normal operation.	
		SD memory card is inserted. Abnormal operation.

GB

# 5 System Set Up

## <Main Controller Menu Tree>

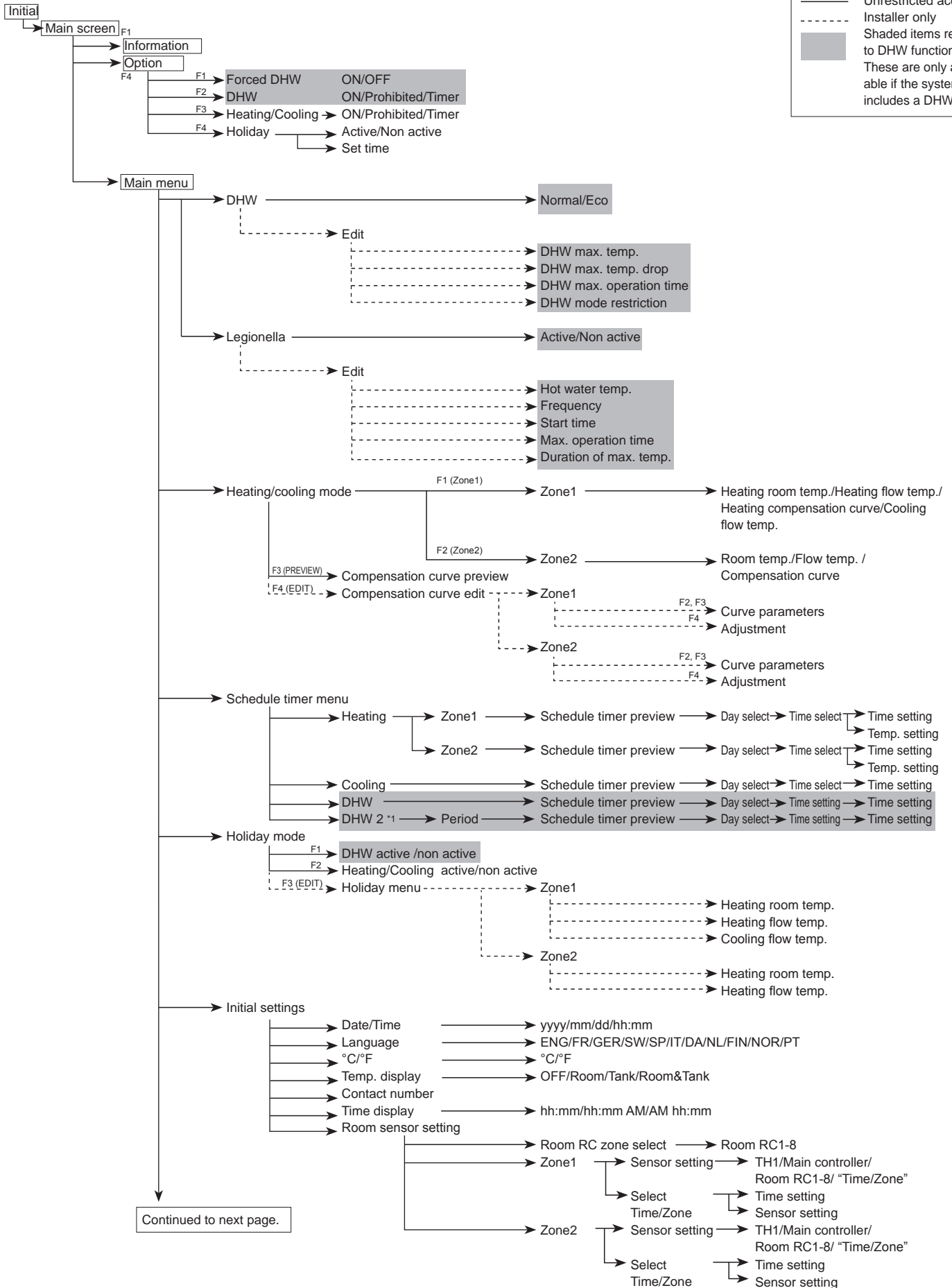

Continued to next page.

\*1 When a PUHZ-FRP outdoor unit is connected.



# 5 System Set Up

## <Main Controller Menu Tree>

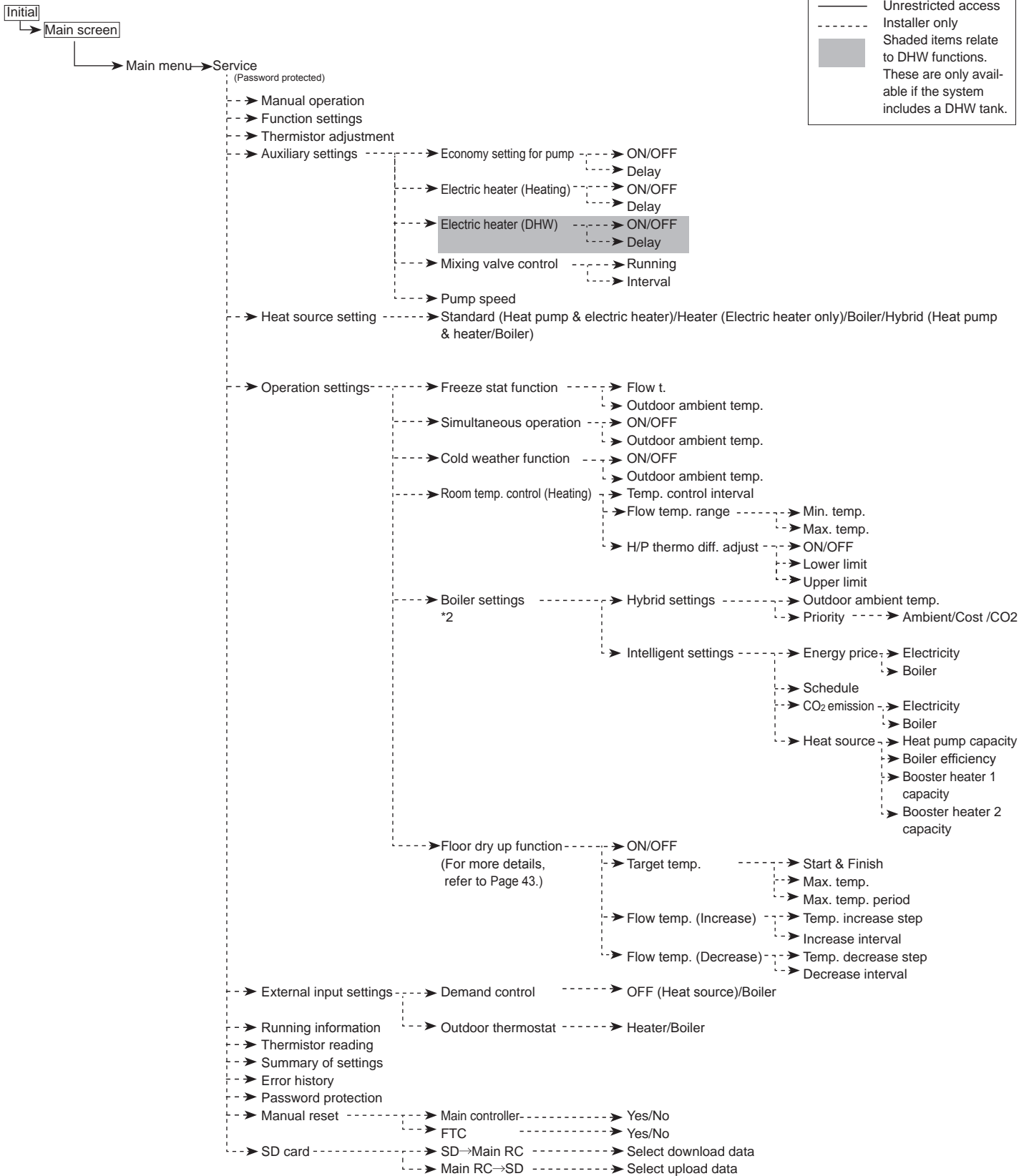

— Unrestricted access  
 - - - - - Installer only  
 ■ Shaded items relate to DHW functions. These are only available if the system includes a DHW tank.

\*2 For more details, refer to the installation manual of PAC-TH011HT-E.

Continued from the previous page.

GB

## 5 System Set Up

### ■ Setting the Main Controller

After the power has been connected to the outdoor unit and hydrobox (See chapter 4.5) the initial system settings can be entered via the main controller.

1. Check all breakers and other safety devices are correctly installed and turn on power to the system.
2. When the main controller switched on for the first time, the screen automatically goes to Initial settings menu, Language setting screen and Date/Time setting screen in order.
3. Main controller will automatically start up. Wait approximately 6 mins whilst the control menus load.
4. When the controller is ready a blank screen with a line running across the top will be displayed.
5. Press button E (Power) (refer to page 27) to turn on the system. Before turning on the system, perform initial settings as instructed below.

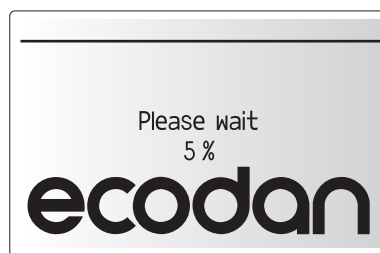

### ■ Main Settings Menu

The main settings menu can be accessed by pressing the MENU button. To reduce the risk of untrained end users altering the settings accidentally there are two access levels to the main settings; and the service section menu is password protected.

#### User Level – Short press

If the MENU button is pressed once for a short time the main settings will be displayed but without the edit function. This will enable the user to view current settings but **NOT** change the parameters.

#### Installer Level – Long press

If the MENU button is pressed down for 3 secs the main settings will be displayed with all functionality available.

The following items can be viewed and/or edited (dependent on access level).

- Domestic Hot water (DHW)
- Heating/Cooling
- Schedule timer
- Holiday mode
- Initial settings
- Service (Password protected)

Use the F2 and F3 buttons to move between the icons. The highlighted icon will appear as a larger version in the centre of the screen. Press CONFIRM to select and edit the highlighted mode.

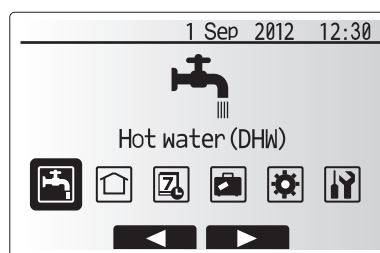

Icon	Description
	Hot water (DHW)
	Heating/Cooling
	Schedule timer
	Holiday mode
	Initial settings
	Service

### ■ Initial Settings

From the Initial settings menu the installer can set the following.

- Date/Time
- Language
- °C/°F
- Temp. display
- Contact number
- Time display
- Room sensor settings

1. Use buttons F1 and F2 to move scroll through the menu list. When the title is highlighted press CONFIRM to edit.
2. Use function buttons appropriate to edit each setting then press CONFIRM to save the setting.

#### <Room sensor settings>

For room sensor settings it is important to choose the correct room sensor depending on the heating mode the system will operate in.

1. From the Initial settings menu select Room sensor settings.

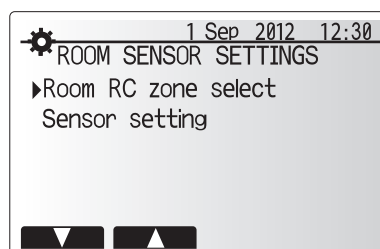
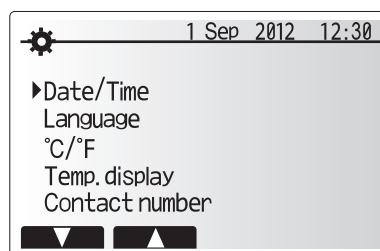

## 5 System Set Up

2. When 2-zone temperature control is active or wireless remote controllers are available, from Room RC zone select screen, select zone no. to assign to each remote controller.

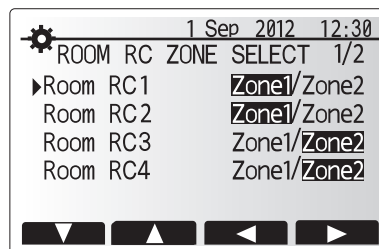

3. From Sensor setting screen, select a room sensor to be used for monitoring the room temperature from Zone1 and Zone2 separately.

Control option (pages 26 and 27)	Corresponding initial settings room sensor	
	Zone1	Zone2
A	Room RC1-8 (one each for Zone1 and Zone2)	*
B	TH1	*
C	Main controller	*
D	*	*

\* Not specified ( if a field-supplied room thermostat is used)

Room RC1-8 (one each for Zone1 and Zone2) (if a wireless remote controller is used as a room thermostat)

4. From Sensor setting screen, select Time/Zone to make it possible to use different room sensors according to the time schedule set in the Select Time/Zone menu. The room sensors can be switched up to 4 times within 24 hours .

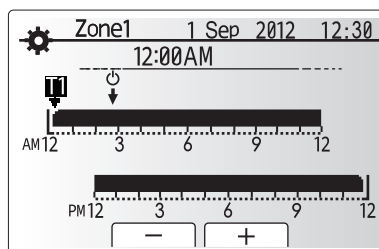
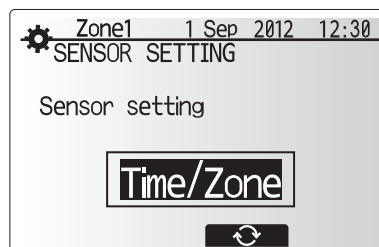
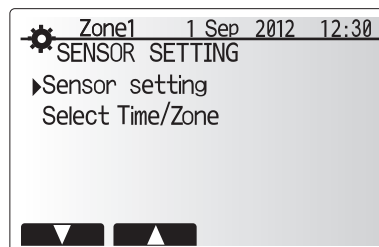

Time/Zone schedule setting screen

### Domestic Hot Water (DHW)/Legionella Prevention

The domestic hot water and legionella prevention menus control the operation of DHW tank heat ups.

#### <DHW mode settings>

1. Highlight the hot water icon and press CONFIRM.
2. Use button F1 to switch between Normal and ECO heating modes.
3. To edit the mode press F2 to display the HOT WATER (DHW) SETTING menu.
4. Use F2 and F3 keys to scroll through the menu selecting each component in turn by pressing CONFIRM. See the table below for description of each setting.
5. Enter the desired number using the function keys and press CONFIRM.

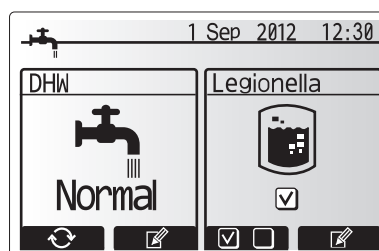

Menu subtitle	Function	Range	Unit	Default value
DHW max. temp	Desired temperature of stored hot water	40 - 60	°C	50
DHW max. temperature drop	Difference in temperature between DHW max. temp and the temperature at which DHW mode restarts	5 - 30	°C	10
DHW max. operation time	Max time allowed for stored water heating DHW mode	30 - 120	min	60
DHW mode restriction	The time period after DHW mode when space heating has priority over DHW mode temporarily preventing further stored water heating (Only when DHW max. operation time has passed.)	30 - 120	min	30

## 5 System Set Up

### Explanation of DHW operation

- When the DHW tank temperature drops from "DHW max. temp" by more than the "DHW max. temperature drop" (set by installer), DHW mode operates and the flow from the primary heating/cooling circuit is diverted to heat the water in the DHW tank.
- When the temperature of the stored water reaches the 'DHW max. temp.' set by the installer or if the 'DHW max. operation time' set by the installer is exceeded DHW mode ceases to operate.
- Whilst DHW mode is in operation primary hot water is not directed to the space heating/cooling circuit.
- Directly after DHW max. operation time 'DHW mode restriction' will routinely operate. The duration of this feature is set by the installer and during its operation DHW mode can not (normally) be reactivated, allowing time for the system to deliver primary hot water to the space heating/cooling if required. However, if at this time there is no current demand for space heating/cooling, the system will automatically resume DHW mode. This will continue until it receives a demand for space heating/cooling.
- After the 'DHW mode restriction' operation the DHW mode can operate again and DHW tank heating will continue according to system demand.

### <Eco mode>

DHW mode can run in either 'Normal' or 'Eco' mode. Normal mode will heat the water in the DHW tank more quickly using the full power of the heat pump. Eco mode takes a little longer to heat the water in the DHW tank but the energy used is reduced. This is because heat pump operation is restricted using signals from the FTC4 based on measured DHW tank temperature.

**Note: The actual energy saved in Eco mode will vary according to outdoor ambient temperature.**

Return to the DHW/legionella prevention menu.

### Legionella Prevention Mode settings (LP mode)

- Use button F3 to choose legionella mode active YES/NO.
- Use button F4 to edit the legionella function.
- Use F1 and F2 keys to scroll through the menu selecting each subtitle in turn by pressing CONFIRM. See the table below for description of each setting.
- Enter the desired number using the function keys and press CONFIRM.

During Legionella Prevention Mode the temperature of the stored water is increased above 60°C to inhibit legionella bacterium growth. It is strongly recommended that this is done at regular intervals. Please check local regulations for the recommended frequency of heat ups.

**Note: When failures occur on the hydrobox, the LP mode may not function normally.**

Menu subtitle	Function	Range	Unit	Default value
Hot water temp.	Desired temp of stored hot water	60–70	°C	65
Frequency	Time between LP mode DHW tank heat ups	1–30	day	15
Start time	Time when LP mode will begin	0:00–23:00	-	03:00
Max. operation time	Maximum time allowed for LP mode DHW tank heat	1–5	hour	3
Duration of max. temp.	The time period after LP mode max. water temp has been reached	1–120	min	30

### Explanation of Legionella Prevention Mode operation

- At the time entered by the installer 'Start time' flow of useful heat from the system is diverted to heat the water in the DHW tank.
- When the temperature of the stored water exceeds the 'Hot Water temp.' set by the installer (above 65°C) primary circuit water is no longer diverted to heat the DHW tank.
- Whilst LP mode is in operation hot water is not directed to the space heating/cooling circuit.
- Directly after LP mode operation 'Duration of max. temp' will operate. The duration of this feature is set by the installer and during its operation stored water temperature will be monitored.
- If stored water temperature should drop to LP restart temp, LP mode will restart and primary water flow from the heat source(s) will be directed to the DHW tank to boost the temperature. Once the set time for Duration of Max. temp has passed LP mode will not recur for the set interval (set by installer).
- It is the responsibility of the installer to ensure the settings for legionella prevention are compliant with local and national guidelines.

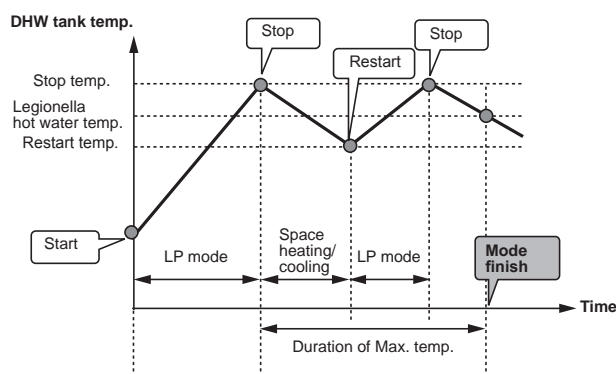
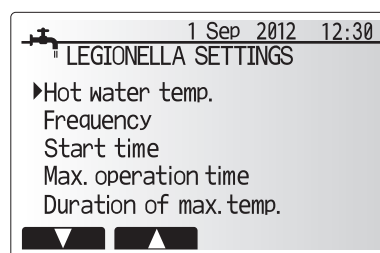
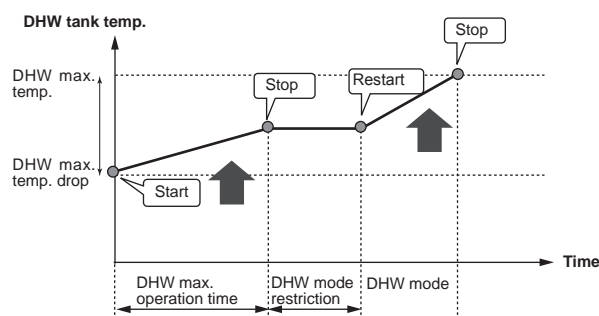
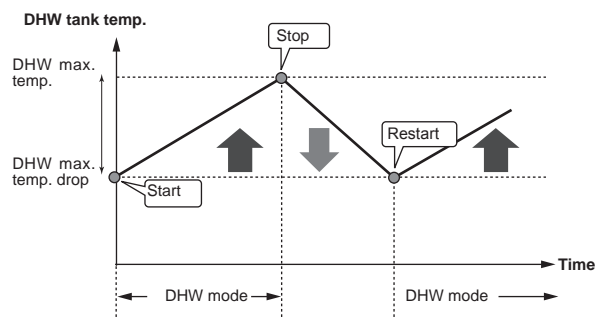

(LP mode: Legionella Prevention mode)

Please note that LP mode uses the assistance of electric heaters (if present) to supplement the energy input of the heat pump. Heating water for long periods of time is not efficient and will increase running costs. The installer should give careful consideration to the necessity of legionella prevention treatment whilst not wasting energy by heating the stored water for excessive time periods. The end user should understand the importance of this feature. **ALWAYS COMPLY WITH LOCAL AND NATIONAL GUIDANCE FOR YOUR COUNTRY REGARDING LEGIONELLA PREVENTION.**

## 5 System Set Up

### Forced DHW

The forced DHW function is used to force the system to operate in DHW mode. In normal operation the water in the DHW tank will be heated either to the set temperature or for the maximum DHW time, whichever occurs first. However should there be a high demand for hot water 'Forced DHW' function can be used to prevent the system from routinely switching to space heating/cooling and continue to provide DHW tank heating.

Forced DHW operation is activated by pressing button F1 and Back button in the 'Option Screen'. After DHW operation finishes, the system will automatically return to normal operation. To cancel forced DHW operation hold down button F1 in the 'Option Screen'.

### ■ Heating/Cooling

The heating and cooling menus deal with space heating and cooling typically using either a radiator or underfloor system depending on the installation.

From the main settings menu

1. Use F2 and F3 buttons to highlight heating/cooling icon then press CONFIRM.
2. The heating and cooling menu will be displayed.
3. To select the sub-menus press the function button below the icon required. E.g. for mode change of Zone1 press F1

Heating/Cooling

1. Under this sub-menu the mode of heating or cooling is selected.
2. Choose between

- Heating flow temperature (🔥)
- Heating room temperature (🏠)
- Heating compensation curve (📈)
- Cooling flow temperature (❄️)

Heating room temperature cannot be selected both in Zone1 and Zone2.

When Cooling flow temp. is selected in Zone1, Cooling flow temp is automatically selected in Zone2. Zone1 and Zone2 are controlled at the same set temperature. If using an underfloor system in Cooling mode, do not set the flow temperature too low to avoid formation of condensation.

3. To choose between the different modes for heating and cooling, highlight the mode preferred and press select.

If compensation curve mode was selected as the heating mode please read the following instructions.

#### Explanation of compensation curve

During late spring and summer usually the demand for space heating is reduced. To prevent the heat pump from producing excessive flow temperatures for the primary circuit the compensation curve mode can be used to maximise efficiency and reduce running costs.

The compensation curve is used to restrict the flow temperature of the primary space heating circuit dependent on the outdoor ambient temperature. The FTC4 uses information from both an outdoor ambient temperature sensor and a temperature sensor on the primary circuit supply to ensure the heat pump is not producing excessive flow temperatures if the weather conditions do not require it.

#### <Compensation curve setting>

\*This setting cannot be performed in cooling mode.

1. From the heating menu select edit using the F3 function button.
2. The compensation curve setting screen will be displayed.
3. In 2-zone heating operation, press F1 to switch between Zone1 and Zone2.
4. Press F2 to alter the Hi parameter (when flow temp is maximum and outdoor ambient temp is minimum).
5. Press F3 to alter the Lo parameter (when flow temp is minimum and outdoor ambient temp is maximum).
6. Press F4 to add an extra point (adjust).

Pressing F2-4 will cause the relevant edit screen to be displayed. Editing Lo and Hi parameters is done in the same way; please see the following for more detailed explanation of parameter editing.

In the parameter (Lo/Hi) edit screen the flow temperature and outdoor ambient temperature for the compensation curve graph can be set and altered for the 2 extremes of Hi and Lo.

1. Press F1 and F2 to change the flow temperature (y-axis of compensation curve).
2. Pressing F1 will raise the desired flow temperature for the set outdoor ambient temperature.
3. Pressing F2 will lower the desired flow temperature for the set outdoor ambient temperature.
4. Press F3 and F4 to change the outdoor ambient temperature (x-axis of compensation curve).
5. Pressing F3 will lower the outdoor ambient temperature for the set flow temperature.
6. Pressing F4 will raise the outdoor ambient temperature for the set flow temperature.

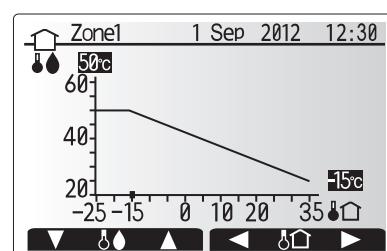
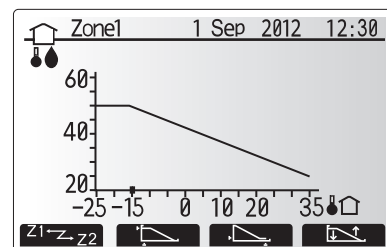
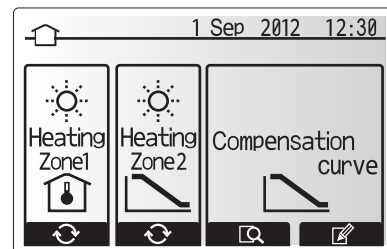

## 5 System Set Up

### ■ Holiday mode

Holiday mode can be activated in 2 ways. Both methods will result in the Holiday Mode activation screen being shown.

#### Option 1.

From the main menu screen button E should be pressed. Be careful not to hold down button E for too long as this will turn off the controller and system.

#### Option 2.

From the main menu screen press button F4. The current settings screen will be displayed. Press button F4 again to access the holiday mode activation screen.

Once the holiday mode activation screen is displayed you can activate/deactivate and select the duration that you would like holiday mode to run for.

- Press button F1 to activate or deactivate holiday mode.
- Use buttons F2, F3 and F4 to input the date which you would like holiday mode to activate or deactivate for space heating/cooling.

#### <Editing holiday mode>

To change the Holiday mode settings e.g. the flow temp, you must access the holiday mode menu from the main settings menu.

1. From main menu screen press button B.
2. Use buttons F2 and F3 to scroll through menu until Holiday Mode is highlighted.
3. Press CONFIRM button.
4. The holiday mode status screen is displayed.
5. To change the flow temperature or room temperatures on heating mode press button F3.
6. A list of variables will be displayed. Choose the one you wish to modify using buttons F1/F2 then press CONFIRM.
7. Adjust the temperature using buttons F3 and F2 and press CONFIRM button to save changes.

### ■ Schedule timer

The schedule timer mode allows daily and weekly space heating/cooling and DHW patterns to be entered.

1. From the main settings menu use F2 and F3 to highlight the schedule timer icon then press CONFIRM.
2. The schedule timer sub menu will be displayed. The icons show the following modes;
  - Heating
  - Cooling
  - Hot Water (DHW)
3. Use F2 and F3 buttons to move between mode icons then press CONFIRM to be shown the preview screen for each mode.

The preview screen allows you to view the current settings. In 2-zone heating operation, press F1 to switch between Zone1 and Zone2. Days of the week are displayed across the top of the screen. Where day appears underlined the settings are the same for all those days underlined. Hours of the day and night are represented as a bar across the main part of the screen. Where the bar is solid black, space heating/DHW (whichever is selected) is allowed.

When a PUIZ-FRP outdoor unit is connected, DHW schedule timer setting can be set for two periods into which a year is divided. In this menu screen, the duration of Period 2 can be entered. The rest of the set duration comes set as Period 1.

1. From the main settings menu use F2 and F3 to highlight the schedule timer icon then press CONFIRM.
2. The schedule timer sub menu will be displayed. The icons show the following modes;
  - Heating
  - Hot Water (DHW)
  - Hot Water (DHW) 2
3. Use F2 and F3 buttons to move between mode icons to select the Hot Water (DHW) 2 icon.
4. Use F1 to F4 buttons to select start and end months that apply to Period 2.
5. Press CONFIRM to be shown the preview screen for each mode.

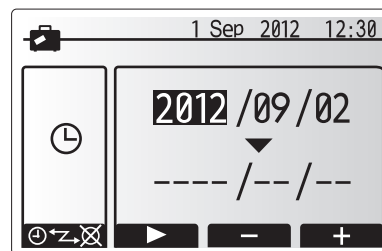

Holiday Mode activation screen

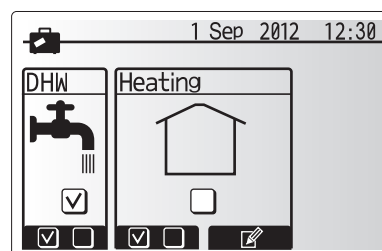

Holiday Mode status screen

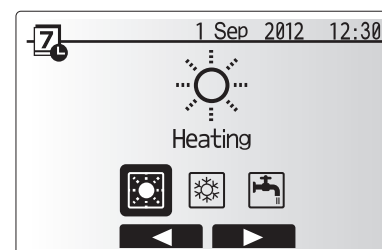

Mode select screen

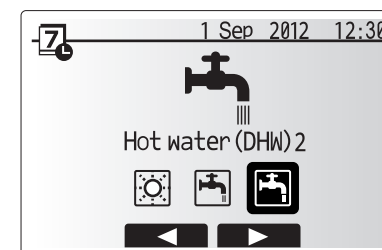

Mode select screen when PUIZ-FRP connected

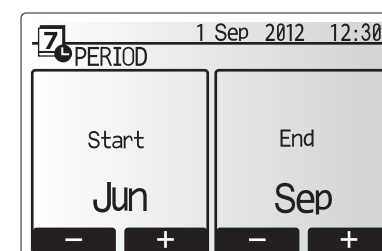

Period setting screen when PUIZ-FRP connected

## 5 System Set Up

### <Setting the schedule timer>

1. In the preview menu screen press F4 button.

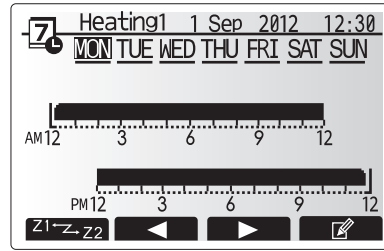

Preview screen

2. First select the days of the week you wish to schedule.  
 3. Press F2/F3 buttons to move between days and F1 to check or uncheck the box.  
 4. When you have selected the days press CONFIRM.

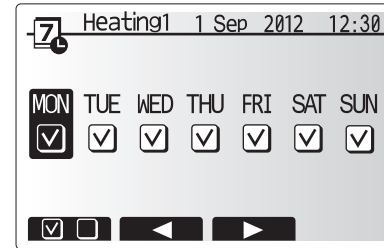

Day of week select screen

5. The time bar edit screen will be displayed.  
 6. Use buttons F2/F3 to move to the point at which you do not want the selected mode to be active press CONFIRM to start.  
 7. Use F3 button to set the required time of inactivity then press CONFIRM.  
 8. You can add up to 4 periods of inactivity within a 24 hour interval.

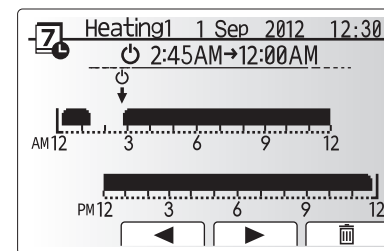

Time of period setting screen 1

9. Press F4 to save settings.

When scheduling heating, button F1 changes the scheduled variable between time and temperature. This enables a lower temperature to be set for a number of hours e.g. a lower temperature may be required at night when the occupants are sleeping.

#### Note:

- The schedule timer for space heating/cooling and DHW are set in the same way. However for Cooling and DHW only time can be used as scheduling variable.
- A small rubbish bin character is also displayed choosing this icon will delete the last unsaved action.
- It is necessary to use the SAVE function F4 button to save settings. CONFIRM does NOT act as SAVE for this menu.

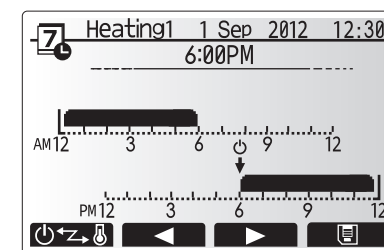

Time of period setting screen 2

## 5 System Set Up

### Service Menu

The service menu provides functions for use by installer or service engineer. It is NOT intended the home owner alters settings within this menu. It is for this reason password protection is required to prevent unauthorised access to the service settings.

1. From the main setting menu use F2 and F3 to highlight the service icon then press CONFIRM.
2. You will be prompted to enter a password. **THE FACTORY DEFAULT PASSWORD IS "0000"**.
3. Press CONFIRM.  
(It takes approx. 30 secs to load the service menu.)

The service menu is navigated using the F1 and F2 buttons to scroll through the functions. The menu is split across two screens and is comprised of the following functions;

1. Manual operation
2. Function settings
3. Thermistor adjustment
4. Auxiliary settings
5. Heat source setting
6. Operation settings
7. External input settings
8. Running information
9. Thermistor reading
10. Summary of settings
11. Error history
12. Password protection
13. Manual reset
14. SD card

In this Installation Manual, instructions will be given only for the following functions;

1. Manual operation
2. Auxiliary settings
3. Heat source setting
4. Operation settings
5. External input settings
6. Password protection
7. Manual reset
8. SD card

Information on the other functions can be found by consulting the service manual.

**Note: Many functions can not be set whilst the indoor unit is running. The installer should turn OFF the unit before trying to set these functions. If the installer attempts to change the settings whilst the unit is running the main controller will display a reminder message prompting the installer to stop operation before continuing. By selecting "Yes" the unit will cease operation.**

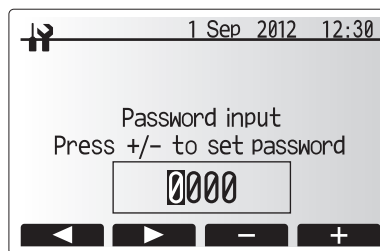

Screen 1 of service menu

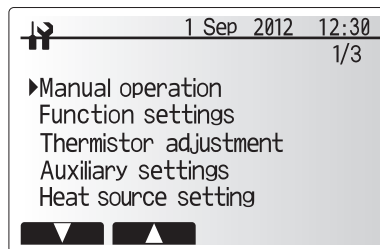

Screen 2 of service menu

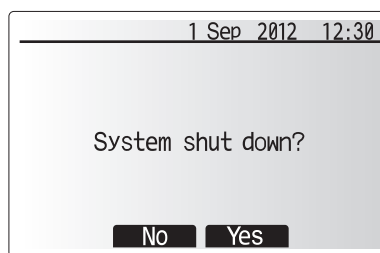

System off prompt screen



## 5 System Set Up

### Manual operation

During the filling of the system the water circulation pump and 3-way valve can be manually overridden using manual operation mode. When manual operation is selected a small timer icon appears in the screen. The function selected will only remain in manual operation for a maximum of 2 hours. This is to prevent accidental permanent override of the FTC4.

1. From the service menu use F1 and F2 buttons to scroll through list until Manual Operation is highlighted.
2. Press CONFIRM.
3. Manual operation menu screen is displayed.
4. To activate manual operation press the function button under the desired part.

#### ►Example

Pressing F3 button will switch manual operation mode ON for the main 3-way valve. When filling of the DHW tank is complete the installer should access this menu again and press F3 to deactivate manual operation of the part. Alternatively after 2 hours manual operation mode will no longer be active and FTC4 will resume control of the part.

**NOTE: Manual operation and heat source setting can not be selected if the system is running. A screen will be displayed asking the installer to stop the system before these modes can be activated. The system automatically stops 2 hours after last operation.**

### Auxiliary settings

This function is used to set the parameters for any auxiliary parts used in the system.

From the service menu use F1 and F2 buttons to highlight Auxiliary settings then press CONFIRM.

#### <Economy settings for pump>

1. From the Auxiliary settings menu highlight Economy Settings for water circulation pump.
2. Press CONFIRM.
3. The economy settings for water circulation pump screen is displayed.
4. Use button F1 to switch the water circulation pump ON/OFF.
5. Use buttons F3 and F4 to adjust the time the water circulation pump will run. (3 - 60 mins)

#### <Electric heater (Heating)>

1. From the Auxiliary settings menu highlight Electric heater (heating).
2. Press CONFIRM.
3. The Electric heater (heating) screen is displayed.
4. Press F1 button to switch the function ON/OFF.
5. Use F3 and F4 buttons to adjust the time period of heat pump only operation before the booster heater will assist in space heating. (5 -180mins)

#### <Electric heater (DHW)>

1. From the Auxiliary settings menu highlight Electric heater (DHW).
2. Press CONFIRM.
3. The Electric heater (DHW) screen is displayed.
4. Press F1 button to switch the function ON/OFF.
5. Use F3 and F4 buttons to adjust the time period of heat pump only operation before the booster heater and the immersion heater (if present) will assist in DHW heating. (15 -30mins)

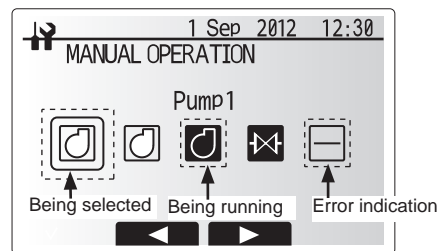

Manual operation menu screen

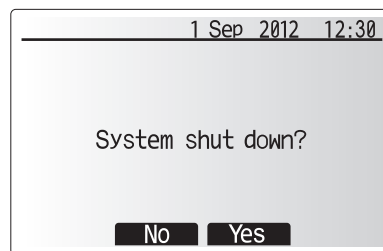

System off prompt screen

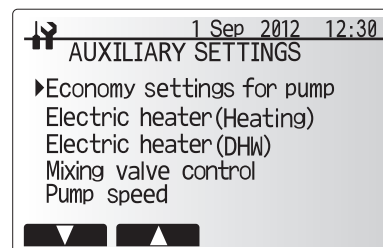

Auxiliary settings menu screen

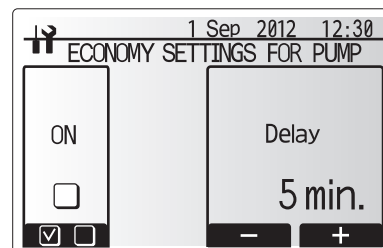

Economy settings for pump screen

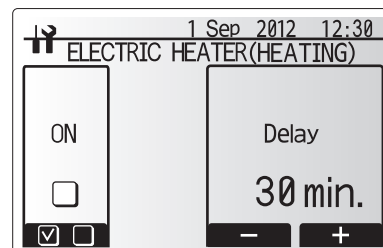

Electric heater (Heating) screen

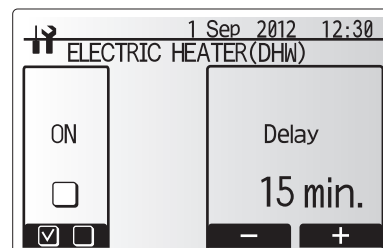

Electric heater (DHW) screen

## 5 System Set Up

### <Mixing valve control>

1. From the Auxiliary settings menu highlight Mixing valve control.
2. Press CONFIRM.
3. The Mixing valve control screen is displayed.
4. Use F1 and F2 buttons to set Running time between 30 to 240 seconds. The Running time equals to a period from full open of the valve (at a hot water mixing ratio of 100%) to full close (at a cold water mixing ratio of 100%).

**Note: Set the Running time according to the specifications of the actuator of each mixing valve.**

1. From the Auxiliary settings menu highlight Mixing valve control.
2. Press CONFIRM.
3. The Mixing valve control screen is displayed.
4. Press F3 and F4 buttons to set the interval between 2-zone temperature controls of the mixing valve between 1 to 30 mins.

**Note: It is recommended to set the interval to 2 minutes that is a default value. With the interval set longer, it could take longer to warm up a room.**



Mixing valve setting screen

### <Pump speed>

1. From the Auxiliary settings menu highlight water circulation pump speed.
2. Press CONFIRM.
3. Press F3 and F4 buttons to select a refrigerant address of which you wish to configure or check the settings.
4. Press CONFIRM.
5. The Pump speed screen is displayed.
6. Use F2 and F3 buttons to set the pump speed of the water circulation pump between 1 to 5.

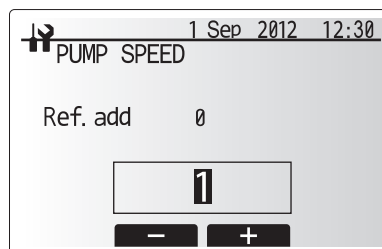

Pump speed setting screen

### Heat source setting

The default heat source setting is heat pump and all electric heaters present in the system to be operational. This is referred to as Standard operation on the menu.

1. From the service menu use F1 and F2 buttons to scroll through list until *Heat Source Setting* is highlighted.
2. Press CONFIRM.
3. Heat source setting menu screen is displayed.
4. Press F3 button until preferred heat source is displayed.
5. Press CONFIRM.



Heat source setting screen

1. If you wish to return to the service menu without saving the setting press return button. You will be asked if you are sure you wish to cancel the changes. Choose Yes or No as appropriate.

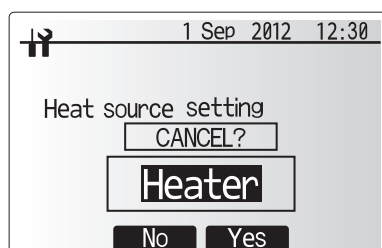

Cancel last action screen

## 5 System Set Up

### Operation settings

1. To access the Operation settings menu use F1 and F2 buttons to scroll through the service menu until Operation settings is highlighted.
2. Press CONFIRM.
3. Operation settings menu is displayed.

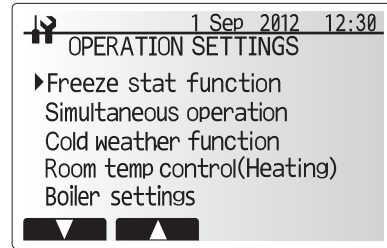

Operation settings menu screen

#### <Freeze stat function>

1. From the Auxiliary settings menu highlight Freeze Stat Function.
2. Press CONFIRM.
3. The freeze stat function screen will be displayed.
4. Use buttons F3 and F4 to adjust the minimum outdoor ambient temperature which freeze stat function will begin to operate, (3 - 20 °C) or choose \*. If asterisk (\*) is chosen freeze stat function is deactivated. (i.e. primary water freeze risk)

**Note: When the system is turned off, freeze stat function is not enabled.**

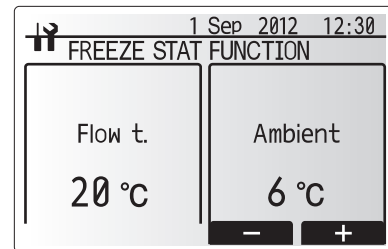

Freeze stat function screen

#### <Simultaneous Operation>

For periods of very low outside temperature this mode can be used. Simultaneous operation allows both DHW and space heating to run together by using the heat pump and/or booster heater to provide space heating whilst only the immersion heater provides heating for DHW. This operation is only available if BOTH a DHW tank AND immersion heater are present on the system.

1. From the Operation settings menu use F1 and F2 buttons to scroll through the list until Simultaneous operation is highlighted.
2. Press CONFIRM.
3. Simultaneous operation screen is displayed.
4. To switch simultaneous operation ON/OFF press F1.
5. To alter the temperature at which simultaneous operation starts use F3 and F4.

#### Note:

- Range of outdoor ambient temperature is  $-15^{\circ}\text{C}$  to  $10^{\circ}\text{C}$  (default  $-15^{\circ}\text{C}$ ).
- System shall automatically return to routine operation. This will happen when the outdoor ambient temp rises above the selected temp for this specific mode of operation.

#### <Cold weather function>

For extremely low outdoor ambient temperature conditions when the heat pump's capacity is restricted the heating or DHW is provided only by the electric booster heater (and immersion if present). This function is intended for use during extreme cold periods only. Extensive use of direct electrical heaters ONLY will result in higher electric usage and may reduce working life of heaters and related parts.

1. From the Operation settings menu use F1 and F2 buttons to scroll through the list until Cold weather function is highlighted.
2. Press CONFIRM.
3. Cold weather function screen is displayed.
4. To switch Cold weather function ON/OFF press F1.
5. To alter the temperature at which heater switching function starts use F3 and F4.

#### Note:

- Range of outdoor ambient temperature is  $-15^{\circ}\text{C}$  to  $-10^{\circ}\text{C}$  (default  $-15^{\circ}\text{C}$ ).
- System shall automatically return to routine operation. This will happen when the outdoor ambient temp rises above the selected temp for this specific mode of operation.

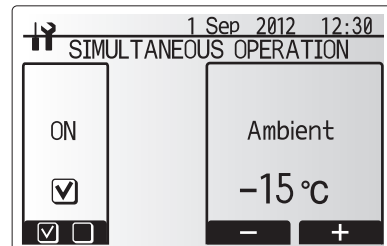

Simultaneous operation screen

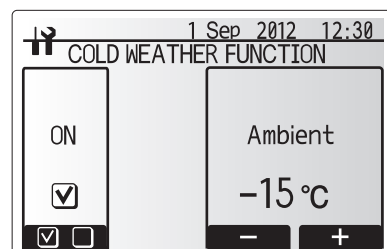

Cold weather function screen

## 5 System Set Up

### <Room Temp Control (Heating)>

This function allows operational setting of flow temperature range from the Ecodan and also the time interval at which the FTC4 collects and processes data for the auto adaptation mode.

1. From the Operation settings menu use F1 and F2 buttons to scroll through the list until Room temp. control (HEATING) is highlighted.
2. Press CONFIRM.
3. Use F1 and F2 keys to scroll through the menu selecting each subtitle in turn by pressing CONFIRM. See the table below for description of each setting.
4. Enter the desired number using the function keys and press CONFIRM.

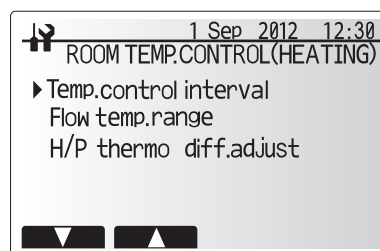

Room temp. control (HEATING) screen

Menu subtitle	Function	Range	Unit	Default	
Temp. control interval	Selectable according to the heat emitter type and the materials of floor (i.e. radiators, floor heating-thick, -thin concrete, wood, etc.)	10 - 60	mins.	10	
Flow temperature range	Minimum temp.	To minimize the loss by frequent ON and OFF in mild outdoor ambient temp. seasons.	25 - 45	°C	30
	Maximum temp.	To set max. possible flow temp according to the type of heat emitters.	35 - 60	°C	50
Heat pump thermo diff.adjust	On/Off	To minimize the loss by frequent ON and OFF in mild outdoor ambient temp. seasons.	On/Off	—	On
	Lower limit	Prohibits heat pump operation until the flow temperature drops below the target flow temperature minus lower limit value.	-9 - -1	°C	-5
	Upper limit	Allows heat pump operation until the flow temperature rises above the target flow temperature plus upper limit value.	+3 - +5	°C	+5

\*1 The minimum flow temperature that prohibits heat pump operation is 20°C.

\*2 The maximum flow temperature that allows heat pump operation equals to the maximum temperature set in the flow temp. range menu.

### <Floor dry up function>

The Floor dry up function automatically changes the target hot water temperature in stages to gradually dry concrete when this particular type of underfloor heating system is installed.

1. Turn off the system using the main controller.
2. From the Operation settings in the service menu, use F1 and F2 buttons to scroll through the list until Floor dry up function is highlighted.
3. Press CONFIRM to display the FLOOR DRY UP screen.
4. To change settings, press F4. For details on settings, refer to the table below.
5. To start the Floor dry up operation, press F1 button to check a box below "Active" and press CONFIRM

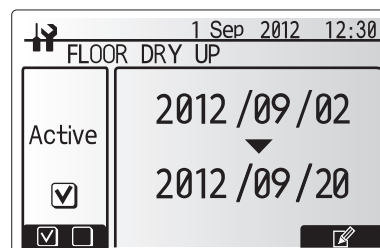

\*1. Upon completion of the operation the system stops all the operations except the Freeze stat. operation.

\*2. For Floor dry up function, the target flow temp. of Zone1 is the same as that of Zone2.

#### Note:

- This function is not available when a PUAZ-FRP outdoor unit is connected.
- Disconnect wiring to signal inputs of room thermostat, demand control, and outdoor thermostat, or the target flow temp. may not be maintained.

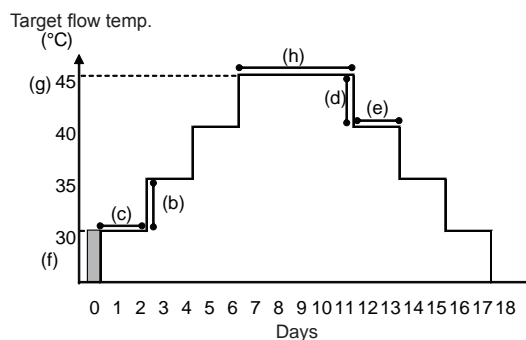

Functions	Symbol	Description	Option/Range	Unit	Default	
Floor dry up function	a	Set the function to ON and power on the system using the main controller, and the dry up heating operation will start.	On/Off	-	Off	
Flow temp. (increase)	Flow temp. increase step	b	Sets the increase step of the target flow temp.	+1 - +10	°C	+5
	Increase interval	c	Sets the period for which the same target flow temp is maintained.	1 - 7	day	2
Flow temp. (decrease)	Flow temp. decrease step	d	Sets the decrease step of the target flow temp.	-1 - -10	°C	-5
	Decrease interval	e	Sets the period for which the same target flow temp is maintained.	1 - 7	day	2
Target temperature	Start & Finish	f	Sets the target flow temp. at the start and the finish of the operation.	25 - 60	°C	30
	Max. target temp.	g	Sets the maximum target flow temp.	25 - 60	°C	45
	Max. temp. period	h	Sets the period for which the maximum target flow temp. is maintained.	1 - 20	day	5

## 5 System Set Up

### External input settings

From the service menu use F1 and F2 buttons to highlight External input settings then press CONFIRM.

#### <Demand control (IN4)>

1. From the External input settings menu highlight Demand control (IN4).
2. Press CONFIRM.
3. The Demand control screen is displayed.

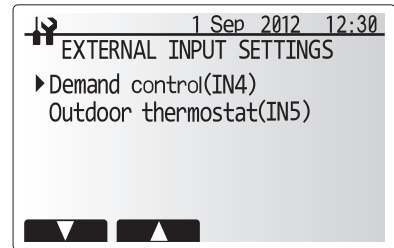

External input settings menu screen

1. Press F3 button to select Heat source OFF or Boiler.
2. Press CONFIRM.

**Note: The selection of "OFF", whilst a signal is being sent to IN4, forcefully stops all the heat source operations and the selection of "Boiler" stops operations of heat pump and electric heater and performs boiler operation.**

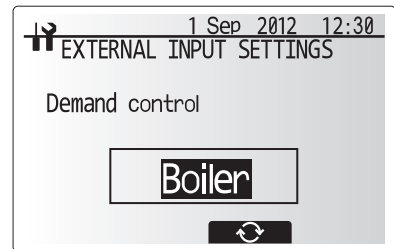

Demand control screen

#### <Outdoor thermostat (IN5)>

1. From the External input settings menu highlight Outdoor thermostat (IN5).
2. Press CONFIRM.
3. The Outdoor thermostat screen is displayed.
4. Press F3 button to select Heater or Boiler.
5. Press CONFIRM.

**Note: The selection of "Heater", whilst a signal is being sent to IN5, performs electric-heater-only operation and the selection of "Boiler" performs boiler operation.**

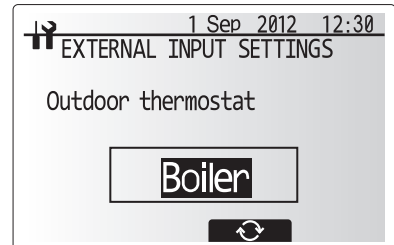

Outdoor thermostat setting screen

### Password protection

Password protection is available to prevent unauthorised access to the service menu by untrained persons.

1. From the service menu use F1 and F2 buttons to scroll through list until *Password protection* is highlighted.
2. Press CONFIRM.
3. When password input screen is displayed use buttons F1 and F2 to move left and right between the four digits, F3 to lower the selected digit by 1, and F4 to increase the selected digit by 1.
4. When you have input your password press CONFIRM.



Password input screen

1. The password verify screen is displayed.
2. To verify your new password press button F3.
3. Your password is now set and the completion screen is displayed.



Password verify screen

#### <Resetting the password>

If you forget the password you entered, or have to service a unit somebody else installed, you can reset the password to the factory default of **0000**.

1. From the main settings menu scroll down the functions until Service Menu is highlighted.
2. Press CONFIRM.
3. You will be prompted to enter a password.
4. Hold down buttons F3 and F4 together for 3 secs
5. You will be asked if you wish to continue and reset the password to default setting.
6. To reset press button F3.
7. The password is now reset to **0000**.



Completion screen

## 5 System Set Up

### Manual reset

Should you wish to restore the factory settings at any time you should use the manual reset function. Please note this will reset ALL functions to the factory default settings.

1. From the service menu use F1 and F2 buttons to scroll through list until Manual Reset is highlighted.
2. Press CONFIRM.
3. The Manual reset screen is displayed.
4. Choose either Manual Reset for FTC4 or Main Controller.

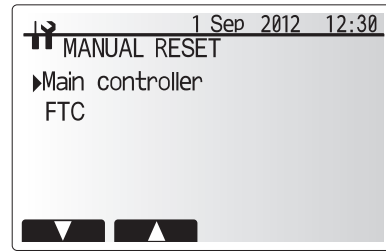

1. Press F3 button to confirm manual reset of chosen device.

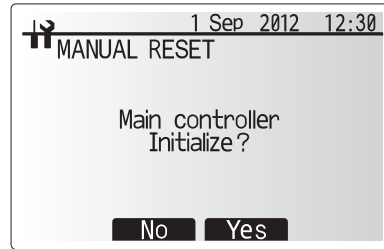

GB

### SD card

The use of an SD memory card simplifies the main controller settings in the field.  
\*Ecodan service tool (for use with PC tool) is necessary for the setting.

#### <SD → Main RC>

1. From the SD card setting use F1 and F2 buttons to scroll through list until "SD → Main RC" is highlighted.
2. Press CONFIRM.
3. Use F1, F2 and F3 buttons to select a menu to write to the main controller.
4. Press CONFIRM to start downloading.
5. Wait for a few minutes until "Complete!" appears.

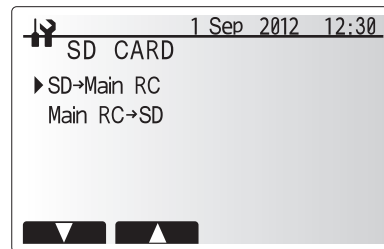

#### <Main RC → SD>

1. From the SD card setting use F1 and F2 buttons to scroll through list until "Main RC → SD" is highlighted.
2. Press CONFIRM.
3. Use F1, F2 and F3 buttons to select a menu to write to the SD memory card.
4. Press CONFIRM to start uploading.
5. Wait for a few minutes until "Complete!" appears.

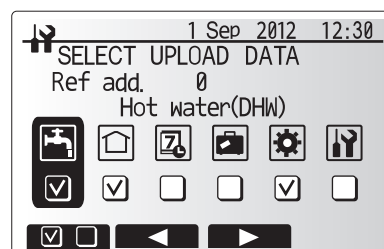
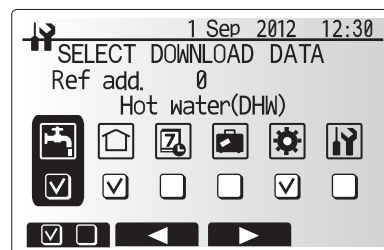

## 6 Commissioning

### ■ Pre-commissioning Checklist

Before commissioning the hydrobox system complete the following table to ensure the necessary checks are carried out.

No	System commissioning checklist				Notes
1	Installation location	Air flow around the unit	Outdoor unit	Good/Poor	
2		Maintenance access	Hydrobox	Good/Poor	
			Outdoor unit	Good/Poor	
3	Water Quality and System Preparation	Water quantity in the primary circuit			L
4	Pipework	Total pipe length	Outdoor to indoor	m	
5		Height difference	Outdoor to indoor	m	
6		System chemically cleansed and flushed		Yes/No	
7		Insulation type and thickness			
8	Electrical wiring	Correct cables used			
9		Electrical maintenance access			Good/Poor
10		Connection of mains power source	Outdoor unit electric cable	Type	
				Size	
			Indoor unit electric cable	Type	
				Size	
11		Connection of control cable			
12	Anti-freeze	Refer to product guidelines. (Also see section 4.2 Note.)			%
13	Check pre-charge in the expansion vessel(s)			Yes/No	
14	Pressurise primary heating circuit to 1 bar			Yes/No	
15	Release air from system			Yes/No	

#### Outdoor unit (PACKAGE type) operation checklist

16	Outdoor unit details		Model No.		Serial No.	
17	Power source (V)	1ø	L - N			
		3ø	L1 - L2	L2 - L3	L3 - L1	
18	Excessive vibration/noise	Compressor		Yes/No		
		Fan		Yes/No		
19	Unit mounted on anti-vibration pads (Tico Pads)			Yes/No		
20	Provision made for condensate removal			Yes/No		

For installation in hard water areas, see advice in section 4.2 General.

Notes/Comments:

## 7 Service and Maintenance

The indoor hydrobox must be serviced **once a year** by a qualified individual. Servicing and maintenance of the outdoor unit should only be done by a Mitsubishi Electric trained technician with relevant qualifications and experience. Any electrical work should be done by a tradesperson with the appropriate electrical

qualifications. Any maintenance or 'DIY' fixes done by a non-accredited person could invalidate the Warranty and/or result in damage to the hydrobox and injury to the person.

### Basic Troubleshooting for Hydrobox

The following table is to be used as a guide to possible problems. It is not exhaustive and all problems should be investigated by the installer or another competent person. Users should not attempt to repair the system themselves.

At no time should the system be operating with the safety devices by-passed or plugged.

Fault symptom	Possible cause	Solution
Cold water at taps (systems with DHW tank)	Scheduled control off period	Check schedule settings and change if necessary.
	All hot water from DHW tank used	Ensure DHW mode is operating and wait for DHW tank to re-heat.
	Heat pump or electric heaters not working	Contact installer.
Heating system does not get up to set temperature.	Prohibit, schedule or holiday mode selected	Check settings and change as appropriate.
	Incorrectly sized radiators	Contact installer.
	The room in which the temperature sensor is located is at a different temperature to the rest of the house.	Reposition the temperature sensor to a more suitable room.
	Battery problem *wireless control only	Check the battery power and replace if flat.
The cooling system does not cool down to the set temperature. (ONLY for ERSC models)	When the water in the circulation circuit is unduly hot, Cooling mode starts with a delay for the protection of the outdoor unit.	Normal operation
	When the outdoor ambient temperature is significantly low, Cooling mode does not start running to avoid freezing of the water pipes.	If the freeze stat. function is not necessary, contact installer to change the settings.
After DHW operation room temperature rises a little.	At the end of the DHW mode operation the 3-way valve diverts hot water away from the DHW tank into space heating circuit. This is done to prevent the cylinder unit components from overheating. The amount of hot water directed into the space heating circuit is dependent on the type of system and the pipe run between the plate heat exchanger and the cylinder unit.	Normal operation no action necessary.
Heating emitter is hot in the DHW mode. (The room temperature rises.)	The 3-way valve may have foreign objects in it, or hot water may flow to the heating side due to malfunctions.	Contact installer.
Schedule function inhibits the system from operating but the outdoor unit operates.	Freeze stat. function is active.	Normal operation no action necessary.
Pump runs without reason for short time.	Pump jam prevention mechanism to inhibit the build up of scale.	Normal operation no action necessary.
Mechanical noise heard coming from cylinder unit	Heaters switching on/off	Normal operation no action required.
	3-way valve changing position between DHW and heating mode.	Normal operation no action necessary.
Noisy pipework	Air trapped in the system	Try bleeding radiators (if present) If the symptoms persist contact installer.
	Loose pipework	Contact installer.
Water discharges from one of the relief valves	The system has overheated or overpressurised	Switch off power to the heat pump and any immersion heaters then contact installer.
Small amounts of water drip from one of the relief valves.	Dirt may be preventing a tight seal in the valve	Twist the valve cap in the direction indicated until a click is heard. This will release a small amount of water flushing dirt from the valve. Be very careful the water released will be hot. Should the valve continue to drip contact installer as the rubber seal may be damaged and need replacing.
An error code appears in the main controller display.	The indoor or outdoor unit is reporting an abnormal condition	Make a note of the error code number and contact installer.

#### <Power failure>

All setting will be saved for 1 week with no power, after 1 week Date/Time ONLY will be saved.

For more details, refer to the service manual.

#### <Draining the hydrobox>

##### WARNING: DRAINED WATER MAY BE VERY HOT

1. Before attempting to drain the hydrobox isolate from the electrical supply to prevent booster heater burning out.
2. Isolate hydrobox from primary water circuit and drain water from hydrobox. Use a suitable heat resistant hose to assist in these operations.
3. Drain any remaining water from booster heater using fitted drain cock and hose to safely drain the unit.
4. After the hydrobox is drained, water remains in the following component parts. Drain water completely by checking the inside of the parts.
  - Strainer (Remove the strainer cover.)
  - Pressure relief valve (Operate the valve.)



## ■ Error Codes

Code	Error	Action
L3	Circulation water temperature overheat protection	Flow rate may be reduced check for; <ul style="list-style-type: none"> <li>• Water leakage</li> <li>• Strainer blockage</li> <li>• Water circulation pump function (Error code may display during filling of primary circuit, complete filling and reset error code.)</li> </ul>
L4	DHW tank water temperature overheat protection	Check the immersion heater and it's contactor.
L5	Indoor unit temperature thermistor (THW1, THW2, THW5, THW6, THW7, THW8, THW9) failure	Check resistance across the thermistor.
L6	Circulation water freeze protection	See Action for L3.
L8	Heating operation error	Re-attach any thermistors that have become dislodged.
L9	Low primary circuit flow rate detected by flow switch (flow switches 1, 2, 3)	See Action for L3. If the flow switch itself does not work, replace it. <b>Caution: The pump valves may be hot, please take care.</b>
LC	Boiler circulation water temperature overheat protection	Check if the setting temperature of the Boiler for heating exceeds the restriction. (See the manual of the thermistors "PAC-TH011HT-E") Flow rate of the heating circuit from the boiler may be reduced. Check for <ul style="list-style-type: none"> <li>• water leakage,</li> <li>• strainer blockage</li> <li>• water circulation pump function.</li> </ul>
LD	Boiler temperature thermistor (THWB1, THWB2) failure	Check resistance across the thermistor.
LE	Boiler operation error	See Action for L8. Check the status of the boiler.
LH	Boiler circulation water freeze protection	Flow rate of the heating circuit from the boiler may be reduced. Check for <ul style="list-style-type: none"> <li>• water leakage</li> <li>• strainer blockage</li> <li>• water circulation pump function.</li> </ul>
LL	Setting errors of Dip switches on FTC4 control board	For boiler operation, check that Dip SW1-1 is set to ON (With Boiler) and Dip SW2-6 is set to ON (With Mixing Tank). For 2-zone temperature control, check Dip SW2-7 is set to ON (2-zone) and Dip SW2-6 is set to ON (With Mixing Tank).
J0	Communication failure between FTC4 and wireless receiver	Check connection cable for damage or loose connections.
P1	Thermistor (Room temp.) (TH1) failure	Check resistance across the thermistor.
P2	Thermistor (Ref. liquid temp.) (TH2) failure	Check resistance across the thermistor.
P6	Anti-freeze protection of plate heat exchanger	See Action for L3. Check for correct amount of refrigerant.
J1 - J8	Communication failure between wireless receiver and wireless remote controller	Check wireless remote controller's battery is not flat. Check the pairing between wireless receiver to wireless remote controller. Test the wireless communication. (See the manual of wireless system)
E0 - E5	Communication failure between main controller and FTC4	Check connection cable for damage or loose connections.
E6 - EF	Communication failure between FTC4 and outdoor unit	Check that the outdoor unit has not been turned off. Check connection cable for damage or loose connections. Refer to outdoor unit service manual.
E9	Outdoor unit receives no signal from indoor unit.	Check both units are switched on. Check connection cable for damage or loose connections. Refer to outdoor unit service manual.
U*, F*	Outdoor unit failure	Refer to outdoor unit service manual.

**Note: To cancel error codes please switch system off (Press button E, on Main Controller, for 3 secs).**

# 7 Service and Maintenance

## Annual Maintenance

It is essential that the hydrobox is serviced at least once a year by a qualified individual any spare parts required **MUST** be purchased from Mitsubishi Electric (safety matter). **NEVER** bypass safety devices or operate the unit without them being fully operational.

### <Annual maintenance points>

Use the Annual Maintenance Log Book as a guide to carrying out the necessary checks on the hydrobox and outdoor unit.

## Annual Maintenance Log Book

Contractor name		Engineer name	
Site name		Site number	

### Hydrobox maintenance record sheet

Warranty number		Model number	
		Serial number	

No.	Mechanical	Frequency	Notes
1	Isolate and drain hydrobox, remove mesh from internal strainer clean and replace.		
2	Open the pressure relief valve, check for unrestricted discharge to the tundish and that the valve reseats correctly. Check there are no blockages in the tundish and associated pipe work.		
3	Drop the primary/heating system pressure to zero check and if necessary top up the expansion relief vessel (1 bar). Air valve of expansion vessel is TR-412.		
4	Check and if necessary top up the concentration of anti-freeze/inhibitor (if used in the system).		
5	Top up the primary/heating system using an appropriate filling loop and re-pressurise to 1 bar.		
6	Heat system and check pressure does not rise above 3 bar and no water is released from the safety valves.		
7	Release any air from the system.		

### Refrigerant models only [EXCEPT EHPX]

1	Refer to outdoor unit manual.	Frequency	Notes
---	-------------------------------	-----------	-------

### Electrical

1	Check condition of cables.	Frequency	Notes
---	----------------------------	-----------	-------

2	Check rating and fuse fitted on the electricity supply.		
---	---	--	--

### Controller

1	Check field settings against factory recommendations.	Frequency	Notes
---	---	-----------	-------

2	Check battery power of wireless thermostat and replace if necessary.		
---	--	--	--

### Outdoor heat pump unit maintenance record sheet

Model number		Serial number	
--------------	--	---------------	--

	Mechanical	Frequency	Notes
1	Inspect grill, heat exchanger fins and air inlet for trapped debris/damage.		
2	Check condensate drain provision.		
3	Check integrity of water pipe work and insulation.		
4	Check all electrical connections.		
5	Check and record the operation voltage.		

\* All the above checks should be carried out once a year.

### Note:

**Within the first couple of months of installation, remove and clean the hydrobox's strainer plus any that are fitted external to the hydrobox. This is especially important when installing on an existing system.**

In addition to annual servicing it is necessary to replace or inspect some parts after a certain period of system operation. Please see tables below for detailed instructions. Replacement and inspection of parts should always be done by a competent person with relevant training and qualifications.

### Parts which require regular replacement

Parts	Replace every	Possible failures
Pressure relief valve (PRV) Air vent (Auto/Manual) Drain cock (Primary circuit) Flexible hose Manometer	6 years	Water leakage due to brass/copper corrosion (Dezincification)

### Parts which require regular inspection

Parts	Check every	Possible failures
Immersion heater	2 years	Earth leakage causing circuit breaker to activate (Heater is always OFF)
Water circulation pump	20,000 hrs (3 years)	Water circulation pump failure

### Parts which must NOT be reused when servicing

- \* O-ring
- \* Gasket

### Note:

Always replace the gasket for pump with a new one at each regular maintenance (every 20,000 hours of use or every 3 years).

# 7 Service and Maintenance

## ■ Engineers Forms (1/2)

Should settings be changed from default, please enter and record new setting in 'Field Setting' column. This will ease resetting in the future should the system use change or the circuit board need to be replaced.

### Commissioning/Field settings record sheet

Main controller screen		Parameters	Default setting	Field setting	Notes	
Main	Zone1 heating room temp		10°C - 30°C	20°C		
	Zone2 heating room temp *1		10°C - 30°C	20°C		
	Zone1 heating flow temp		25°C - 60°C	45°C		
	Zone2 heating flow temp *1		25°C - 60°C	35°C		
	Cooling flow temp *2		5°C - 25°C	15°C		
	Zone1 heating compensation curve		-9°C - + 9°C	0°C		
	Zone2 heating compensation curve *1		-9°C - + 9°C	0°C		
Holiday mode		Active/Non active/Set time	-			
Option	Forced DHW operation		On/Off	-		
	DHW		On/Off/Timer	On		
	Heating		On/Off/Timer	On		
	Holiday mode		Active/Non active/Set time	-		
Setting	DHW *3	Operation mode		Normal/Eco	Normal	
		DHW max. temp.		40°C - 60°C	50°C	
		DHW temp. drop		5°C - 30°C	10°C	
		DHW max. operation time		30 - 120 mins	60 mins	
		DHW mode restriction		30 - 120 mins	30 mins	
	Legionella prevention *3	Active		Yes/No	Yes	
		Hot water temp		60°C - 70°C	65°C	
		Frequency		1 - 30 days	15 days	
		Start time		00.00 - 23.00	03.00	
		Max. operation time		1 - 5 hours	3 hours	
	Heating/Cooling *2	Duration of maximum temp.		1 - 120 mins	30 min	
		Zone1 operation mode		Heating room temp/Heating flow temp/Heating compensation curve/Cooling flow temp	Room temp	
	Compensation curve	Hi set point	Zone2 operation mode *1		Heating room temp/Heating flow temp/Heating compensation curve	Compensation curve
			Zone1 outdoor ambient temp		-15°C - +35°C	-15°C
			Zone1 flow temp		25°C - 60°C	50°C
			Zone2 outdoor ambient temp *1		-15°C - +35°C	-15°C
		Lo set point	Zone2 flow temp *1		25°C - 60°C	40°C
			Zone1 outdoor ambient temp		-15°C - +35°C	35°C
			Zone1 flow temp		25°C - 60°C	25°C
			Zone2 outdoor ambient temp *1		-15°C - +35°C	35°C
Adjust		Zone2 flow temp *1		25°C - 60°C	25°C	
		Zone1 outdoor ambient temp		-14°C - +34°C	—	
		Zone1 flow temp		25°C - 60°C	—	
		Zone2 outdoor ambient temp *1		-14°C - +34°C	—	
Holiday	Zone2 flow temp *1		25°C - 60°C	—		
	DHW *3		Active/Non active	Non active		
	Heating/Cooling *2		Active/Non active	Active		
	Zone1 heating room temp		10°C - 30°C	15°C		
	Zone2 heating room temp *1		10°C - 30°C	15°C		
	Zone1 heating flow temp		25°C - 60°C	35°C		
	Zone2 heating flow temp *1		25°C - 60°C	25°C		
Initial settings	Cooling flow temp *2		5°C - 25°C	25°C		
	Language		ENG/FR/GER/SW/SP/IT/DA/NL/FIN/NOR/PT	ENG		
	°C/°F		°C/°F	°C		
	Temp. display		Room/DHW tank/Room&DHW tank /Off	Off		
	Time display		hh:mm/hh:mm AM/AM hh:mm	hh:mm		
	Room sensor settings for Zone1		TH1/Main RC/Room RC1-8/"Time/Zone"	TH1		
	Room sensor settings for Zone2 *1		TH1/Main RC/Room RC1-8/"Time/Zone"	TH1		
Service menu	Room RC zone select *1		Zone1/Zone2	Zone1		
	Thermistor adjustment	THW1		-10°C - +10°C	0°C	
		THW2		-10°C - +10°C	0°C	
		THW5		-10°C - +10°C	0°C	
		THW6		-10°C - +10°C	0°C	
		THW7		-10°C - +10°C	0°C	
		THW8		-10°C - +10°C	0°C	
		THW9		-10°C - +10°C	0°C	
		THWB1		-10°C - +10°C	0°C	
	Auxiliary settings	THWB2		-10°C - +10°C	0°C	
		Economy settings for pump		On/Off	On	
		Electric heater (Heating)		Time before pump switched off (3 - 60 mins) *4	10 mins	
		Electric heater (DHW) *3		Space heating: On (used)/Off (not used)	On	
		Mixing valve control		Electric heater delay timer (5 - 180 mins)	30 mins	
		Pump speed		DHW: On (used)/Off (not used)	On	
		Electric heater delay timer (15 - 30 mins)	15 mins			
		Running time (10 - 240 secs)	120 secs			
		Interval (1 - 30 mins)	2 mins			
		Pump speed (1 - 5)	5			

\*1 The settings related to Zone2 can be switched only when Zone2 temperature control is enabled (when Dip SW2-6 and SW 2-7 are ON).

\*2 Cooling mode settings are available for ERSC-VM2B only.

\*3 Only available if DHW tank present in system.

\*4 Decreasing "time before pump switched off" may increase the duration of stand-by in Heating mode.

# 7 Service and Maintenance

## Engineers Forms (2/2)

Commissioning/Field settings record sheet (continued from the previous page)

Main controller screen			Parameters	Default setting	Field setting	Notes	
Service menu	Heat source setting	Standard/Heater/Boiler/Hybrid *5		Standard			
		Operation settings	Freeze stat function	Outdoor ambient temp. (3 - 20°C)	5°C		
	Simultaneous operation (DHW/ Heating)		On/Off *6	Off			
	Cold weather function	Outdoor ambient temp. (-15 - +10°C)		-15°C			
		On/Off *6	Off				
	Room temp control (Heating)	Outdoor ambient temp. (-15 - -10°C)		-15°C			
		Temp. control interval (10 - 60 mins)		10 mins			
	Flow temp. range	Min. temp. (25 - 45°C)	30°C				
			Max. temp. (35 - 60°C)	50°C			
		Heat pump thermo diff. adjust		On/Off *6		On	
			Lower limit (-9 - -1°C)	-5°C			
	Upper limit (+3 - +5°C)	5°C					
		Boiler operation	Hybrid settings		Outdoor ambient temp. (-15 - +10°C)	-15°C	
	Priority mode (Ambient/Cost/CO <sub>2</sub> )		Ambient				
	Intelligent settings	Energy price *7	Electricity (0.001 - 999 */kWh)	0.5 */kWh			
			Boiler (0.001 - 999 */kWh)	0.5 */kWh			
		CO <sub>2</sub> emission	Electricity (0.001 - 999 kg -CO <sub>2</sub> /kWh)	0.5 kg -CO <sub>2</sub> /kWh			
			Boiler (0.001 - 999 kg -CO <sub>2</sub> /kWh)	0.5 kg -CO <sub>2</sub> /kWh			
		Heat source	Heat pump capacity (1 - 40 kW)		11.2 kW		
			Boiler efficiency (25 - 150%)		80%		
			Booster heater 1 capacity (1 - 20 kW)		2 kW		
			Booster heater 2 capacity (1 - 20 kW)		4 kW		
	Floor dry up function	On/Off *6		Off			
		Target temp.	Start&Finish (25 - 60°C)		30°C		
			Max. temp. (25 - 60°C)		45°C		
			Max. temp. period (1 - 20 days)		5 days		
		Flow temp. (Increase)	Temp. increase step (+1 - +10°C)		+5°C		
			Increase interval (1 - 7 days)		2 days		
		Flow temp. (Decrease)	Temp. decrease step (-1 - -10°C)		-5°C		
			Decrease interval (1 - 7 days)		2 days		
External input settings	Demand control (IN4)	Heat source OFF/Boiler operation		Boiler operation			
	Outdoor thermostat (IN5)	Heater operation/Boiler operation		Boiler operation			

\*5 When Dip SW1-1 is set to OFF "WITHOUT Boiler" or SW2-6 is set to OFF "WITHOUT Mixing tank", neither Boiler nor Hybrid can be selected.

\*6 On: the function is active; Off: the function is inactive.

\*7 "\*" of "\*/kwh" represents currency unit (e.g. € or £ or the like)

### ■ Refrigerant collecting (pumpdown) for split model systems only

Refer to "Refrigerant collection" in the outdoor unit installation manual or service manual.

### ■ Back-up operation of boiler

Heating operation is backed up by boiler.

For more details, refer to the installation manual of PAC-TH011HT-E.

#### <Installation & System set up>

1. Set Dip-SW 1-1 to ON "With boiler" and SW2-6 to ON "With Mixing tank".
2. Install the thermistors THWB1 (Flow temp.) and THWB2 (return temp.) \*1 on the boiler circuit.
3. Connect the output wire (OUT10: Boiler operation) to the signal input (room thermostat input) on the boiler. \*2
4. Install one of the following room temp. thermostats. \*3

- Wireless remote controller (option)
- Room temp. thermostat (field supply)
- Main controller (remote position)

\*1 The boiler temp. thermistor is an optional part.

\*2 OUT10 has no voltage across it.

\*3 Boiler heating is controlled on/off by the room temp. thermostat.

#### <Remote controller settings>

1. Go to Service menu > Heat source setting and choose "Boiler" or "Auto". \*3
2. Go to Service menu > Operation settings > Boiler settings to make detailed settings for "Auto" above .

\*3 The "Auto" automatically switches heat sources between Heat pump (and Electric heater) and boiler.

### ■ Multiple outdoor units control

To realize bigger systems by using multiple outdoor units, up to 6 units of the same model can be connected.

The hydrobox can be used as a slave unit for multiple outdoor unit control.

For more details, refer to the installation manual of PAC-IF051/052B-E.

#### <Dip switch setting>

- Set Dip SW4-1 to ON "Active: multiple outdoor unit control".
- Keep Dip SW4-2 OFF (default setting) (master/slave setting: slave).
- Set Dip SW1-3 to ON when the hydrobox is connected to a DHW tank.

Installers: Please be sure to put your contact address/telephone number on  
this manual before handing it to the customer.

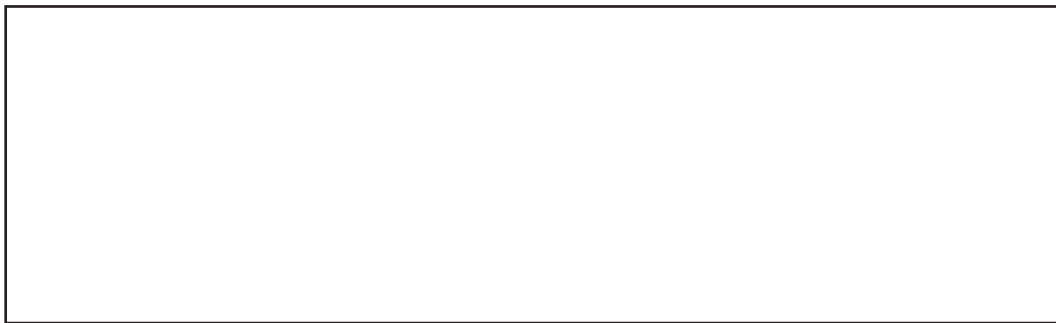

## **mitsubishi electric corporation**

HEAD OFFICE: TOKYO BLDG., 2-7-3, MARUNOUCHI, CHIYODA-KU, TOKYO 100-8310, JAPAN  
Authorized representative in EU: MITSUBISHI ELECTRIC EUROPE B.V.  
HARMAN HOUSE, 1 GEORGE STREET, UXBRIDGE, MIDDLESEX UB8 1QQ, U.K.  
This product is made by Mitsubishi Electric Air Conditioning Systems Europe Ltd.: NETTLEHILL Rd, HOUSTOUN IND ESTATE,  
LIVINGSTON, EH54 5EQ, UK